

TOWER CABINET

84", 86 1/4", 92 1/4" & 98 1/4"
Walk in

Assembly Guide

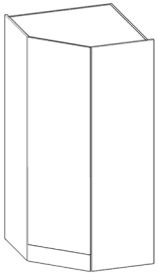

1 Door

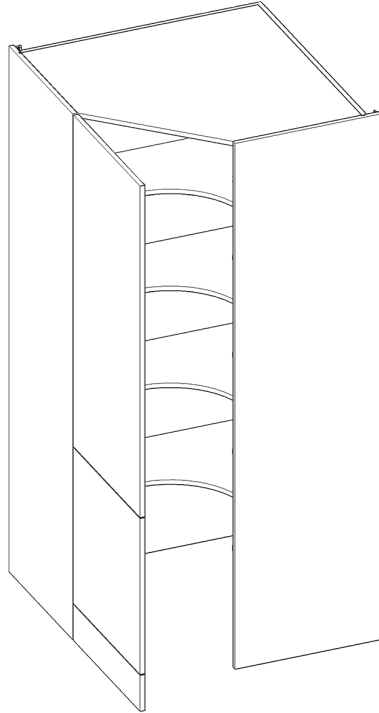

84" x 24"

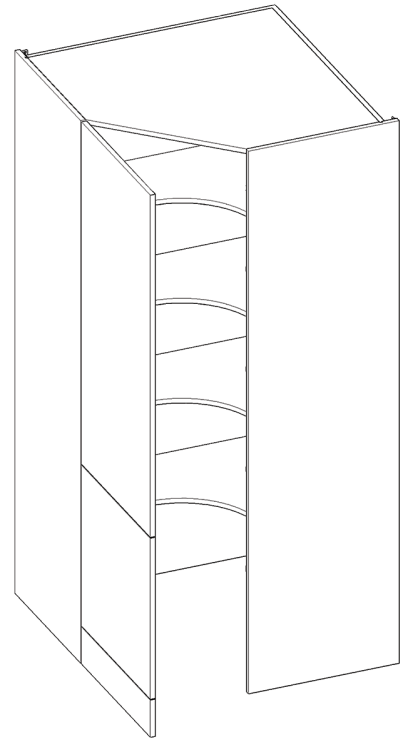

86 1/4" x 24"

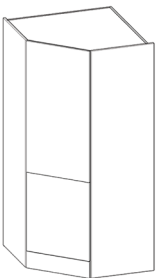

70/30 Door

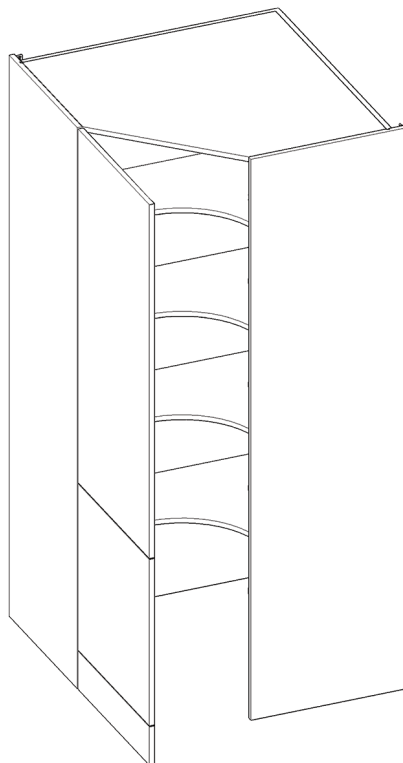

92 1/4" x 24"

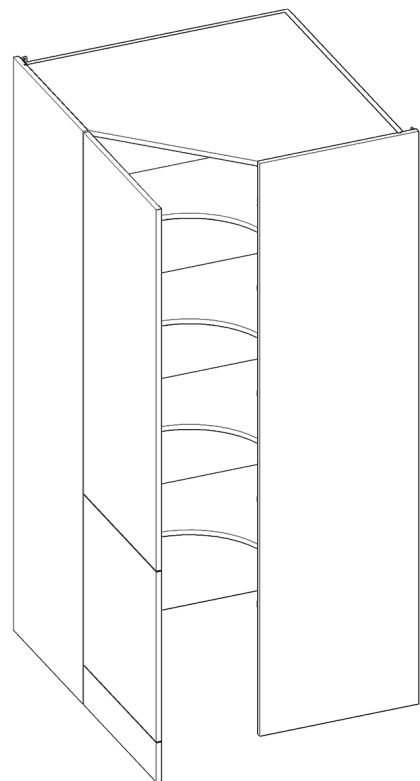

98 1/4" x 24"

wren
KITCHENS

TOWER CABINET

84", 86 1/4", 92 1/4" & 98 1/4"
Walk in

Assembly Guide

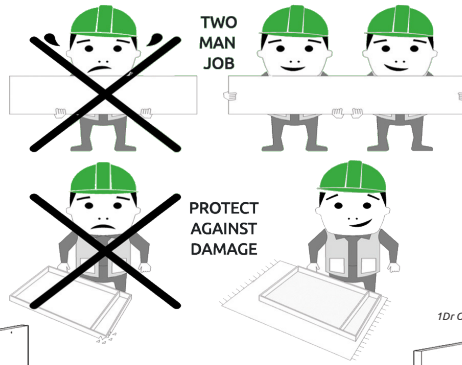

BEFORE YOU START

INSTALLATION SHOULD BE PERFORMED BY A COMPETENT PERSON ONLY.

THIS PRODUCT COULD BE DANGEROUS IF INCORRECTLY INSTALLED

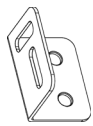
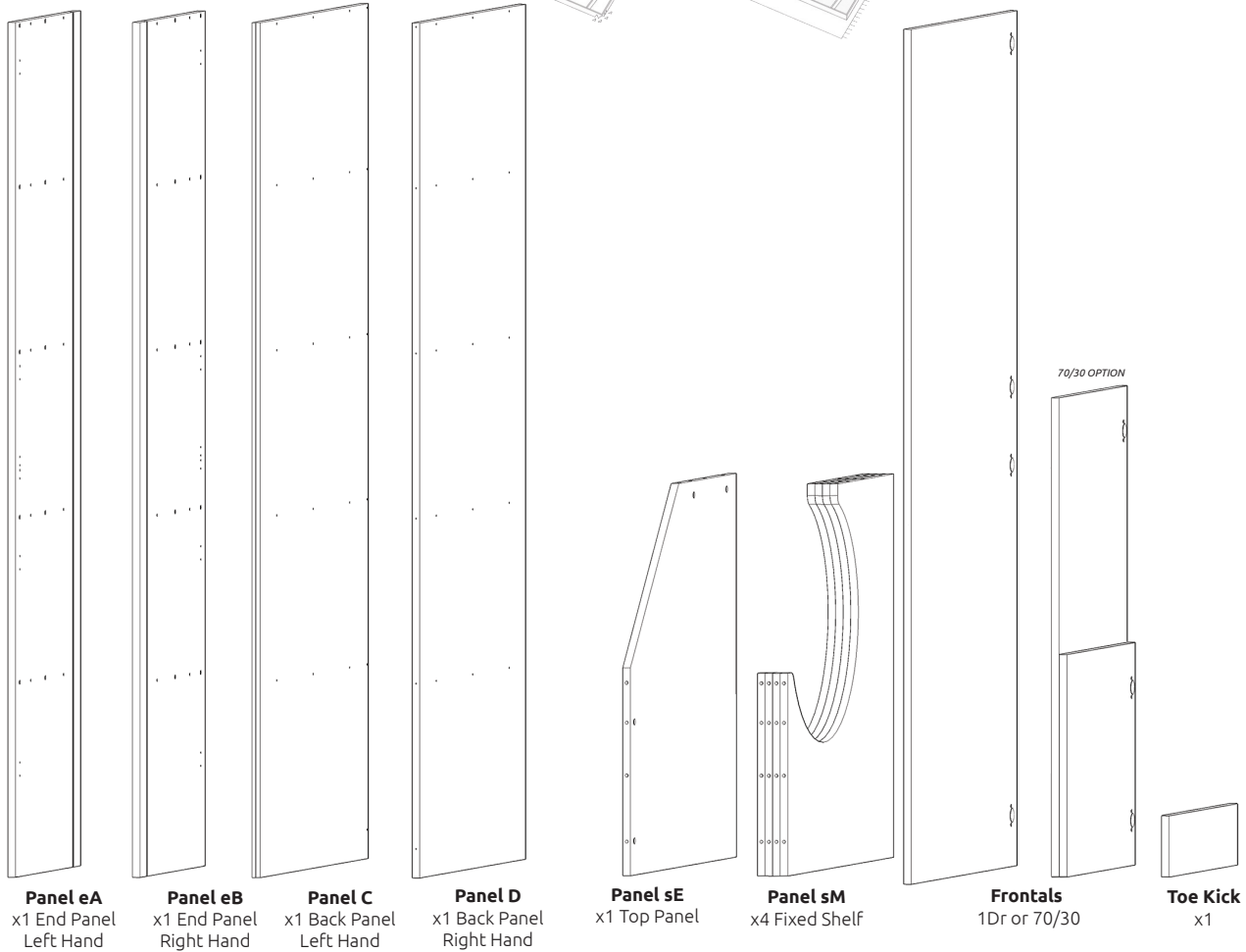

(K) L Bracket LGE
x4

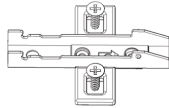

Hinge Mounting Plate
Inc Screws

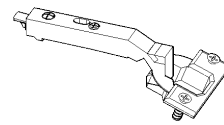

Hinge
Inc Screws

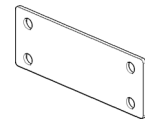

Fixing Plate (FF)
x4

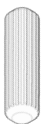

(Aa) x40
Wooden Dowel



(Cc) x20
Cam Dowel



(Dd) x20
Cam lock

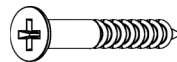

(H) x36 1 1/4" Screws

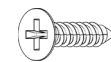

(B) x12 5/8" Screws



(M) x8
Cover Cap
(Per Colour)

REQUIRED TOOLS



TOWER CABINET

84", 86 1/4", 92 1/4" & 98 1/4"
Walk in

Assembly Guide

Step 1.

Seat cam dowel (Cc) into holes in end panel (eA) as shown.

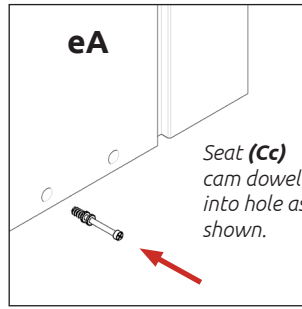
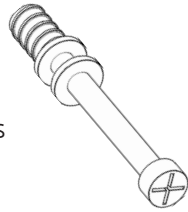

Step 2.

Seat dowel (Aa) into holes in end panel (eA) as shown.

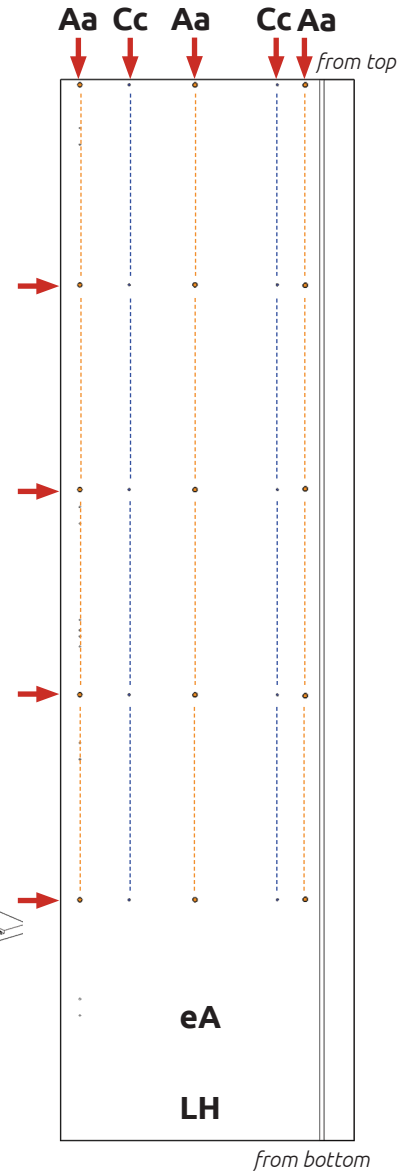
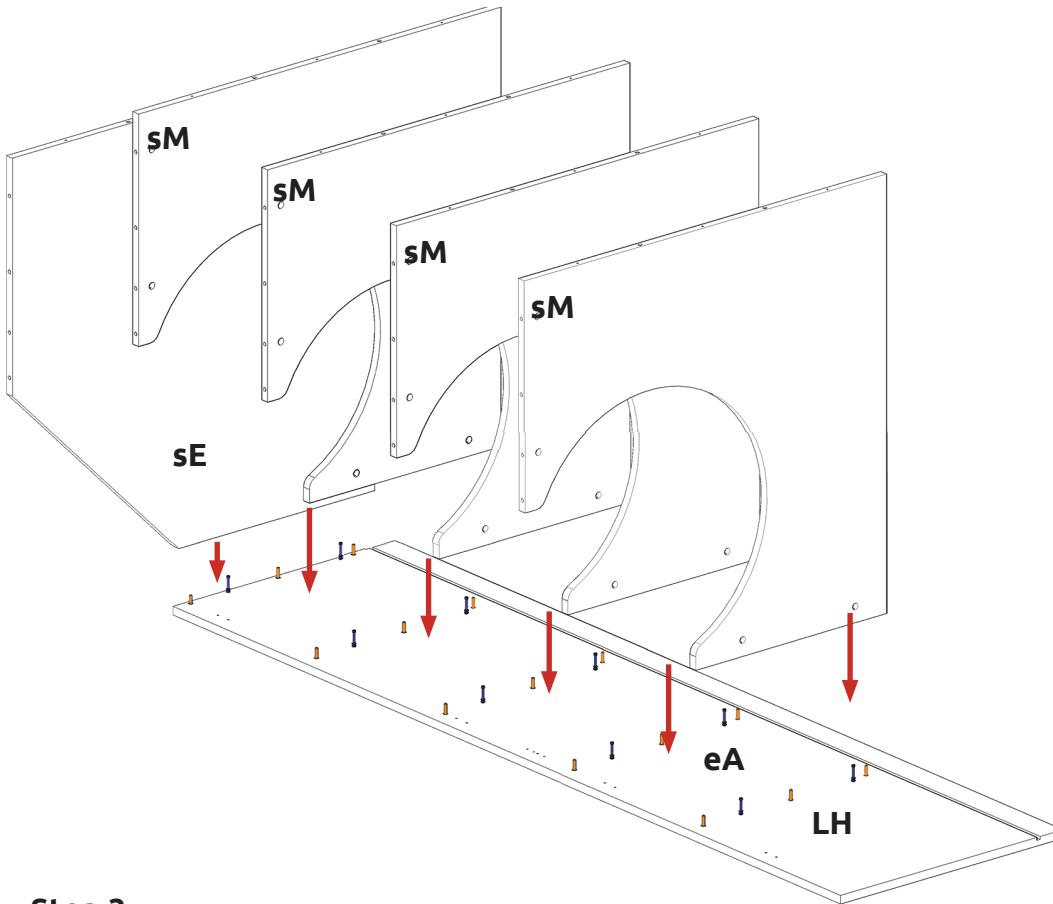

Step 3.

Attach panels (sM) and (sE) to panels (eA), using cam dowel (Cc) (in blue) and dowels (Aa) (in orange) in positions as shown.

Do **not** use power tools with cam dowel (Cc) or cam lock (Dd)

DOWEL (Aa) & CAM DOWEL (Cc) LOCATION DETAIL

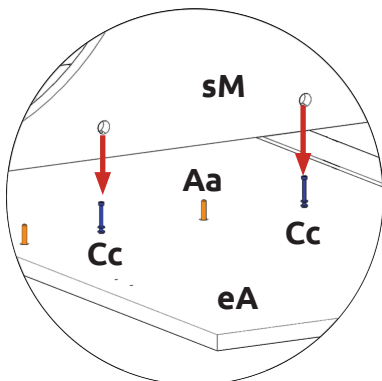

View from underside

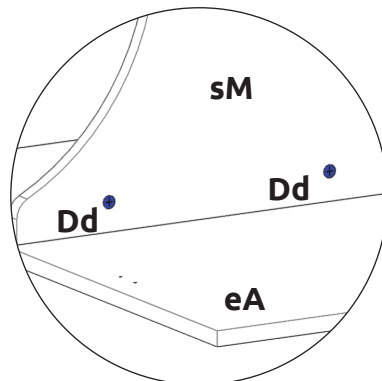

View from underside

Step 4.

Join panels (sE) and (sM) to end panel (eA). Insert cam locks (Dd). Do NOT tighten until Step 7.



TOWER CABINET

84", 86 1/4", 92 1/4" & 98 1/4"

Walk in

Assembly Guide



Step 5.

Seat 10x dowels (**Aa**) into holes in both panels (**sM**) and (**sE**) as shown.

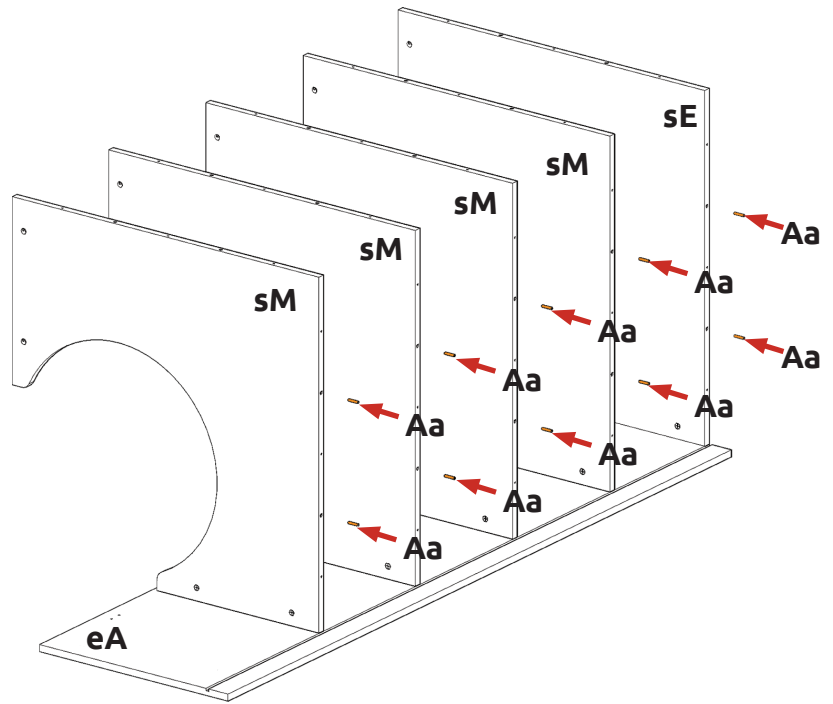

Step 6.

Slide back panel (**C**) into groove of end panel (**eA**). Also insert dowels (**Aa**) (in orange) from panels (**sM**) and (**sE**) into the required holes in back panel (**C**).

Once back panel (**C**) is in position, ensure the panel is flush & square with bottom of end panel (**eA**).

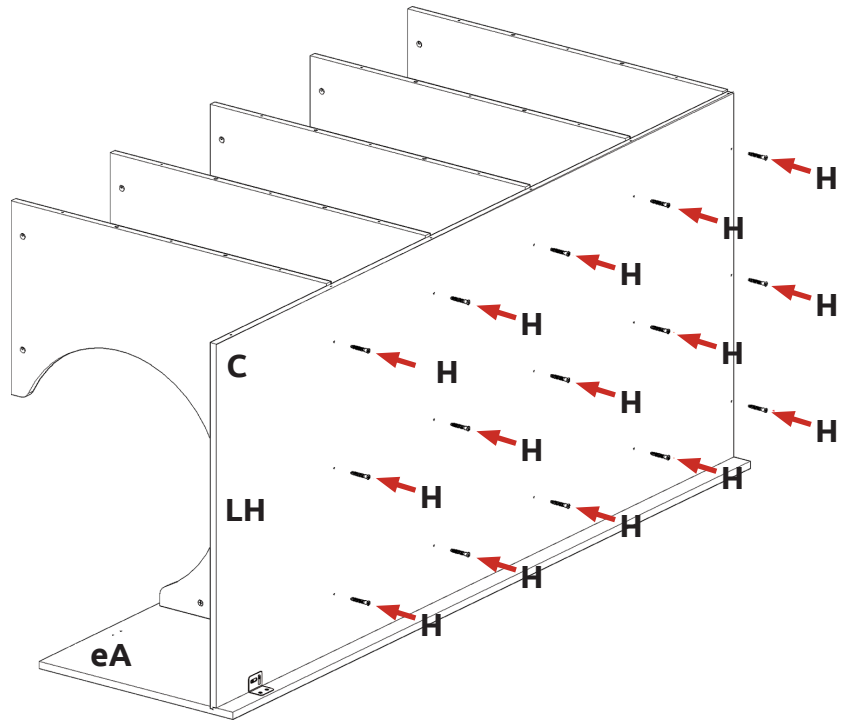

Step 7.

Hand tighten all cam locks (**Dd**), this will expand cam dowels (**Cc**).

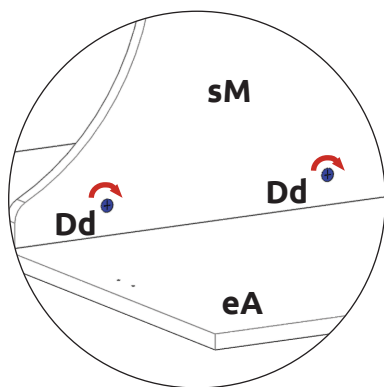

View from underside

Step 8.

Using 15 x 1 1/4" screws (**H**) secure back panel (**C**) to panels (**sM**) and (**sE**).

Step 9.

Secure back panel (**C**) to end panel (**eA**) at the bottom. Use 4 x 5/8" screws (**B**) to 1 x L bracket LGE (**K**), as shown.

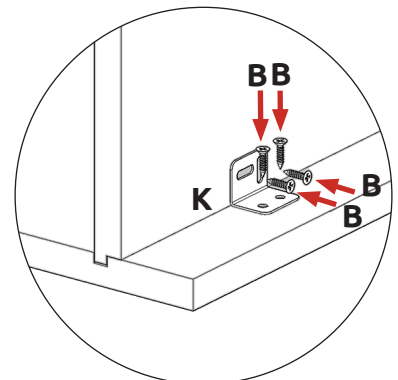

TOWER CABINET

84", 86 1/4", 92 1/4" & 98 1/4"
Walk in

Assembly Guide

Step 10.

Seat dowel (Aa) into holes in end panel (eB) as shown.

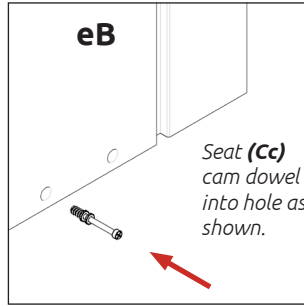

Step 11.

Seat cam dowel (Cc) into holes in end panel (eB) as shown.

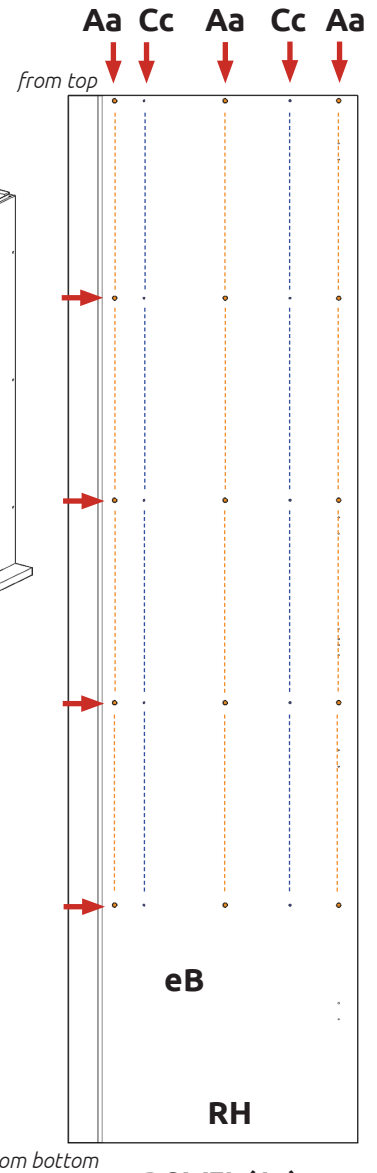
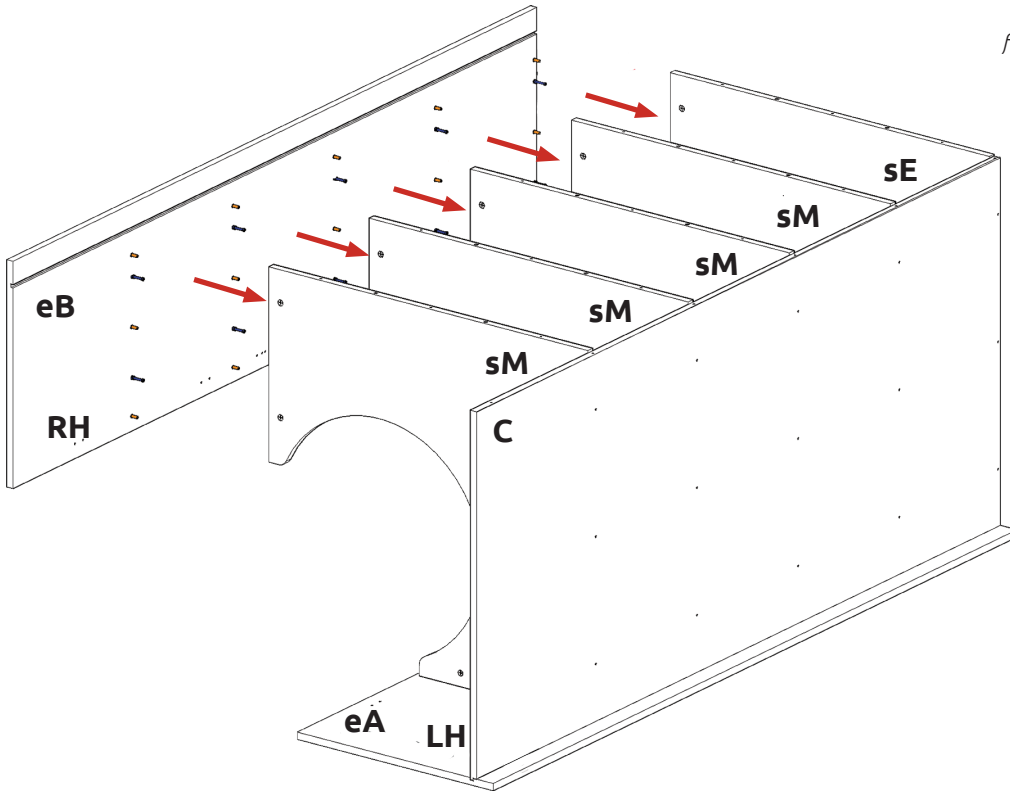

**DOWEL (Aa)
& CAM DOWEL (Cc)
LOCATION DETAIL**

Step 12.

Attach end panel (eB) to panels (sM) and (sE) using cam dowel (Cc) (in blue) and dowels (Aa) (in orange) in positions as shown.

Do **not** use power tools with cam dowel (Cc) or cam lock (Dd)

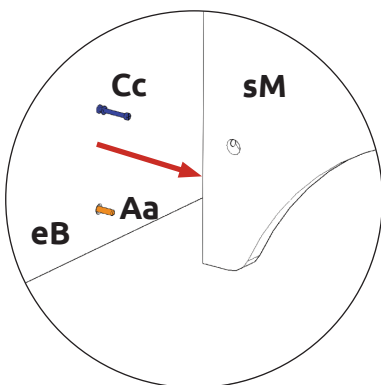

View from underside

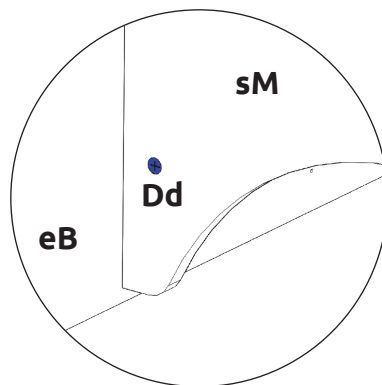

View from underside



Step 13.

Join panels (sE) and (sM) to end panel (eB).
Insert cam locks (Dd).
Do NOT tighten until Step 18.



TOWER CABINET

84", 86 1/4", 92 1/4" & 98 1/4"

Walk in

Assembly Guide



Step 14.

Seat 10x dowels (**Aa**) into holes in both panels (**sM**) and (**sE**) as shown.

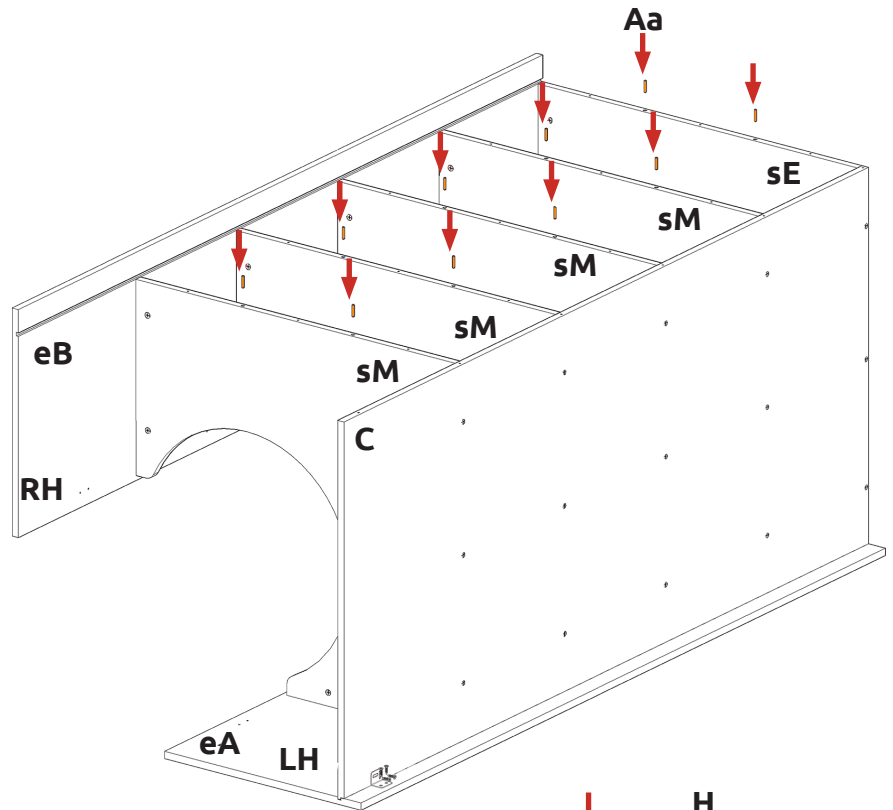

Step 15.

Secure back panel (**D**) to panels (**sM**) and (**sE**) and back panel (**C**). Use 20 x 1 1/4" screws (**H**) as shown.

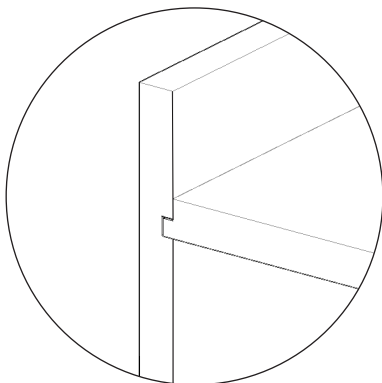
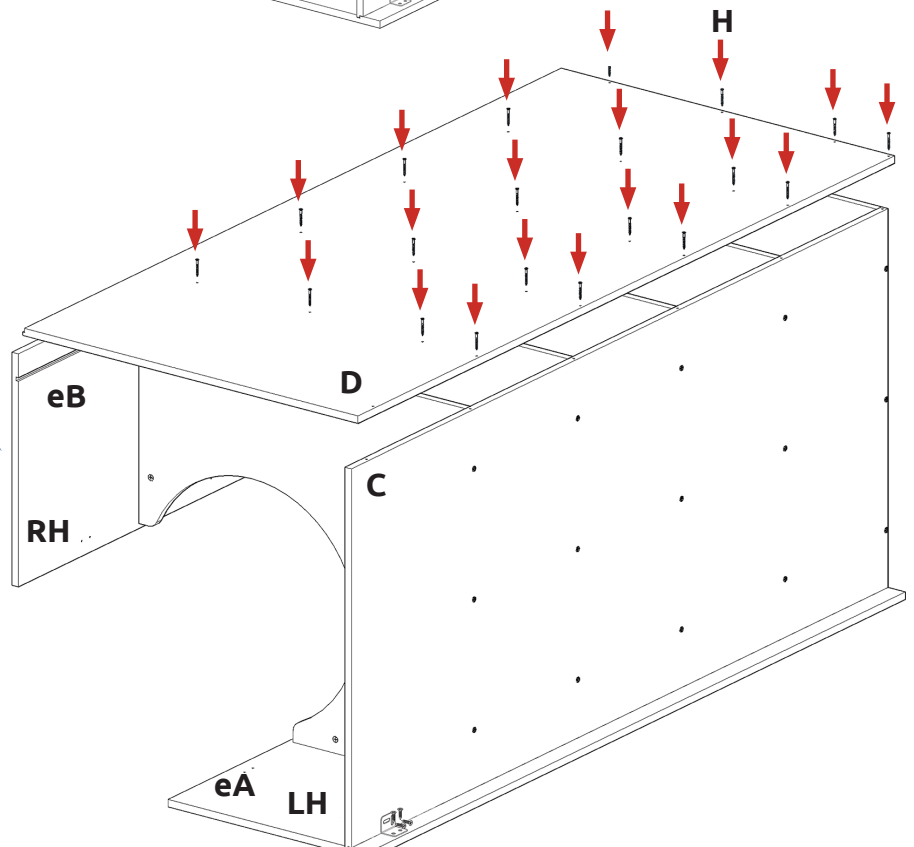

Step 16.

Ensure to insert the lower position of back panel (**D**) into end panel (**eB**) groove.

TOWER CABINET

84", 86 1/4", 92 1/4" & 98 1/4"
Walk in

Assembly Guide

Step 17.

Secure back panel (D) to end panel (eB) at the bottom. Use 4 x 5/8" screws (B) to 1 x L bracket LGE (K), as shown.

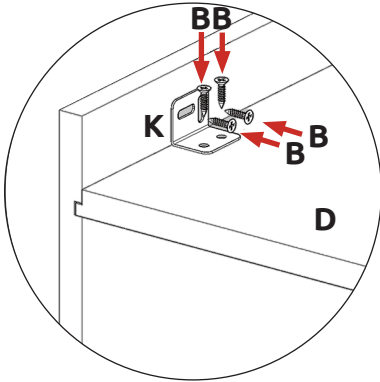

Step 18.

Hand tighten all the remaining cam locks (Dd), this will expand cam dowels (Cc) and tighten the cabinet together.

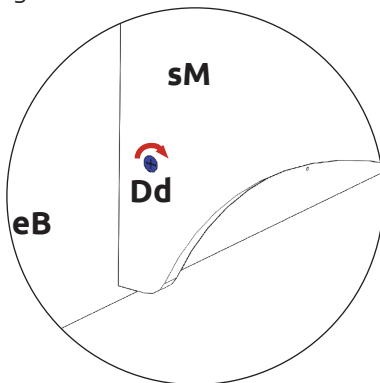

View from underside

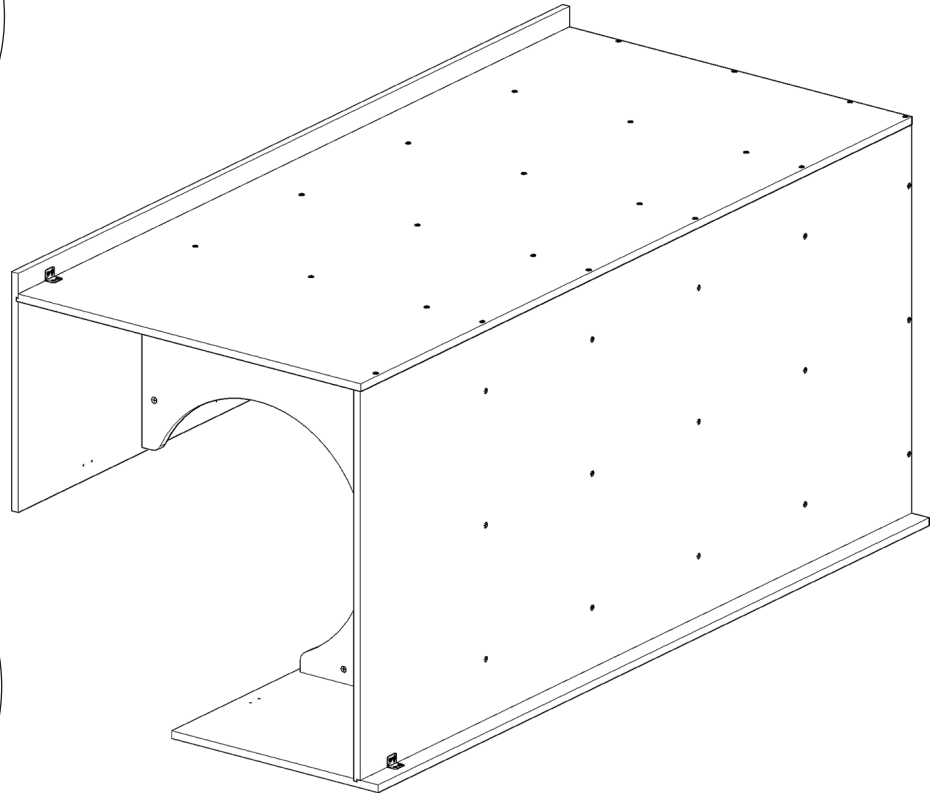

Step 19.

Secure tower to the wall using L brackets LGE (K). Use 2 x 5/8" screws (B) to secure each of the L brackets LGE (K) to the cabinets at either side. Then screw through into the wall as shown.

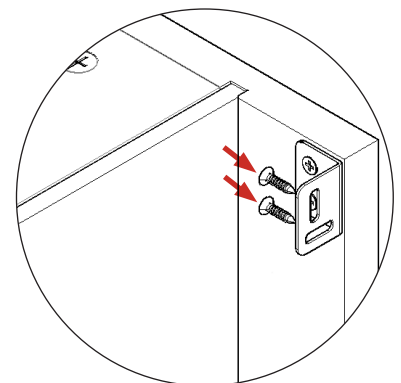
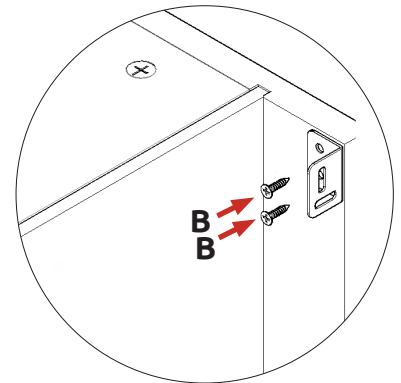

Screws for fixing to walls are not provided as these vary depending on your wall material and construction. Ensure appropriate fixings for wall constructions are used.

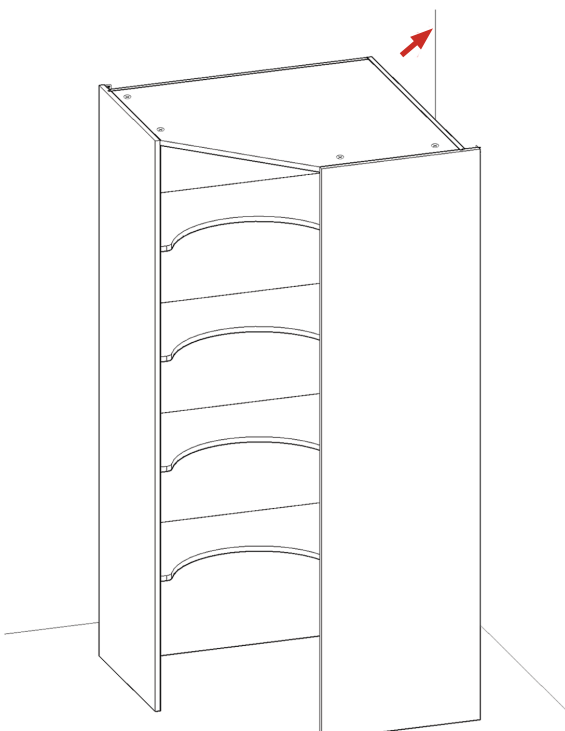

TOWER CABINET

84", 86 1/4", 92 1/4" & 98 1/4"
Walk in

Assembly Guide

Step 20.

Attach hinge plates onto end panel (**eA**) or (**eB**) to suit as shown.

Hinge side to be mounted in accordance to customer specific kitchen plan.

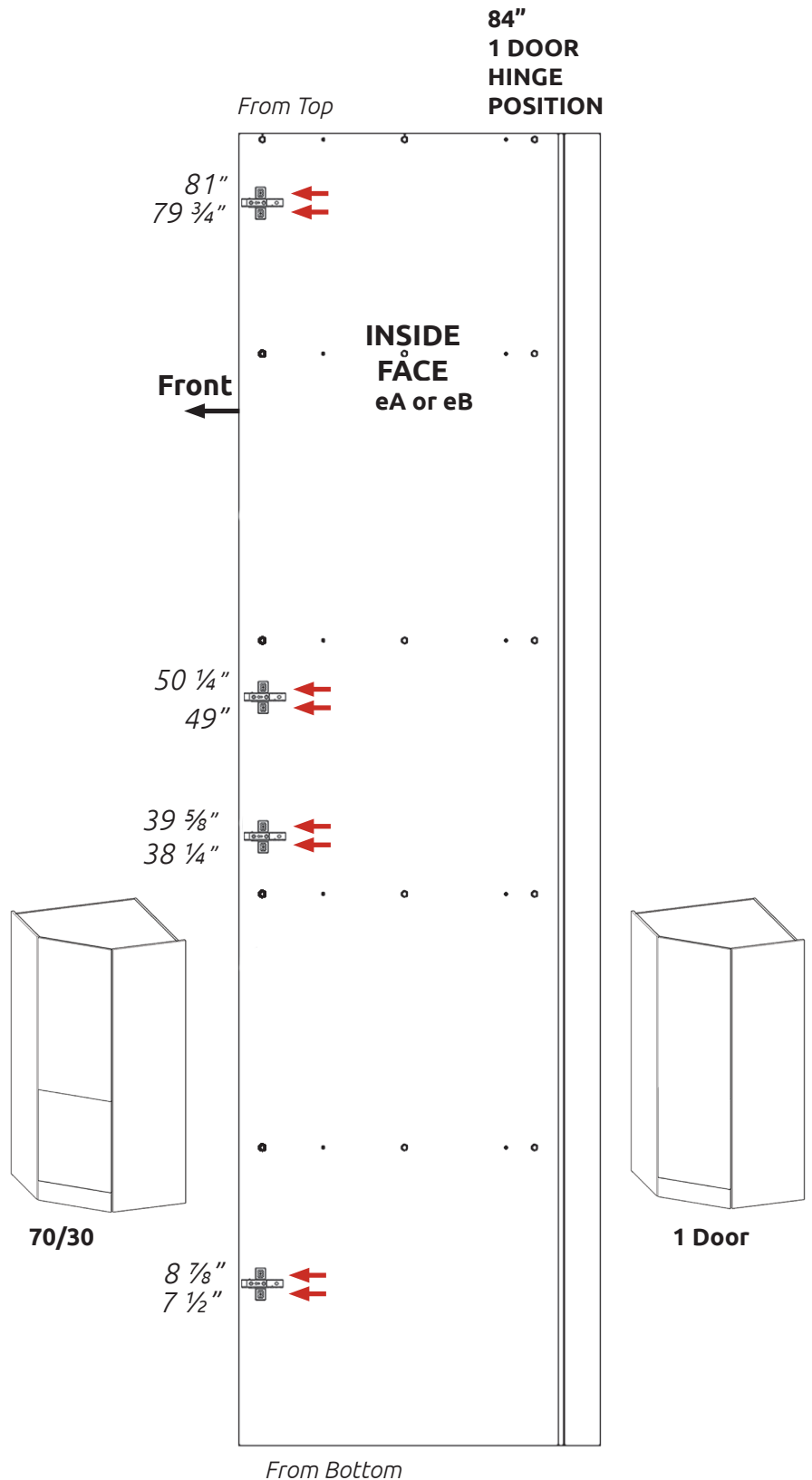
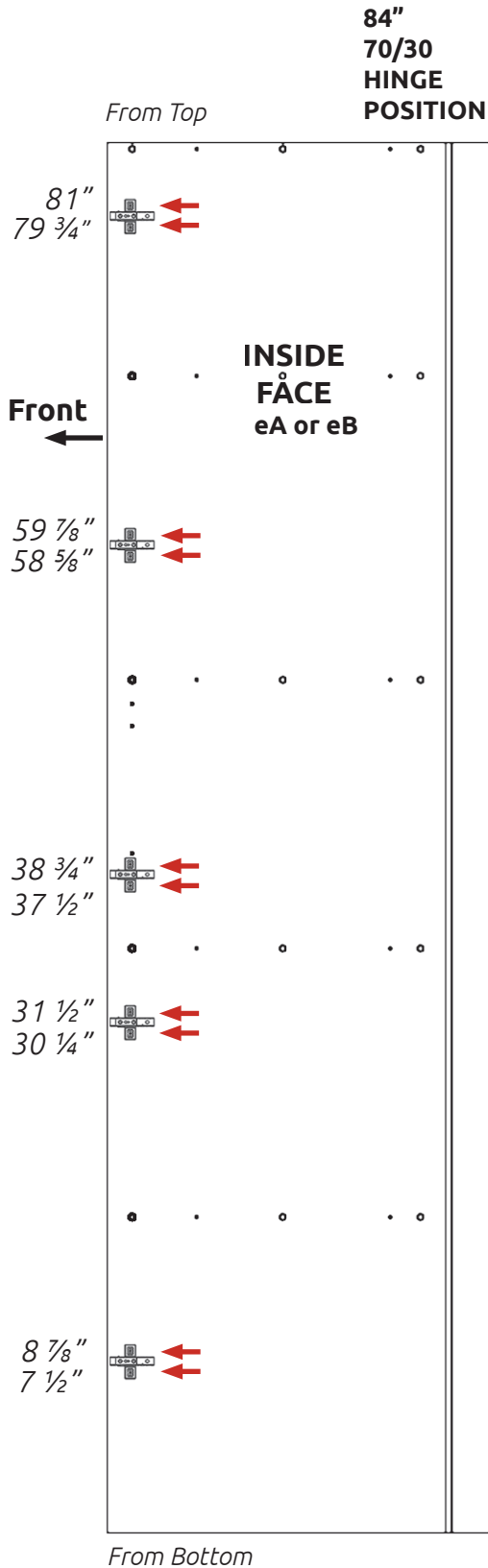

TOWER CABINET

84", 86 1/4", 92 1/4" & 98 1/4"
Walk in

Assembly Guide

Step 20.

Attach hinge plates onto end panel (**eA**) or (**eB**) to suit as shown.

Hinge side to be mounted in accordance to customer specific kitchen plan.

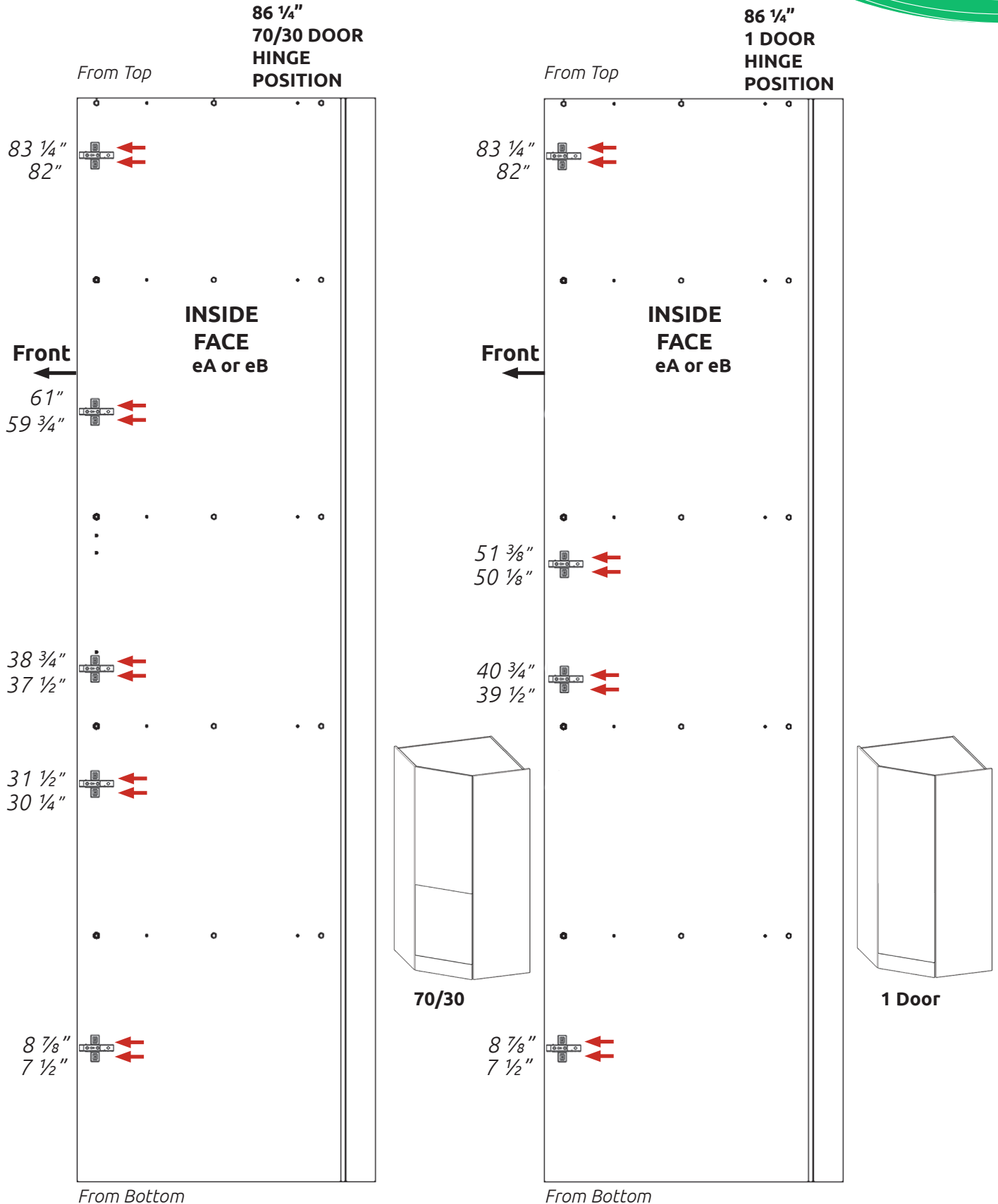

TOWER CABINET

84", 86 1/4", 92 1/4" & 98 1/4"

Walk in

Assembly Guide

Step 20.

Attach hinge plates onto end panel (**eA**) or (**eB**) to suit as shown.

Hinge side to be mounted in accordance to customer specific kitchen plan.

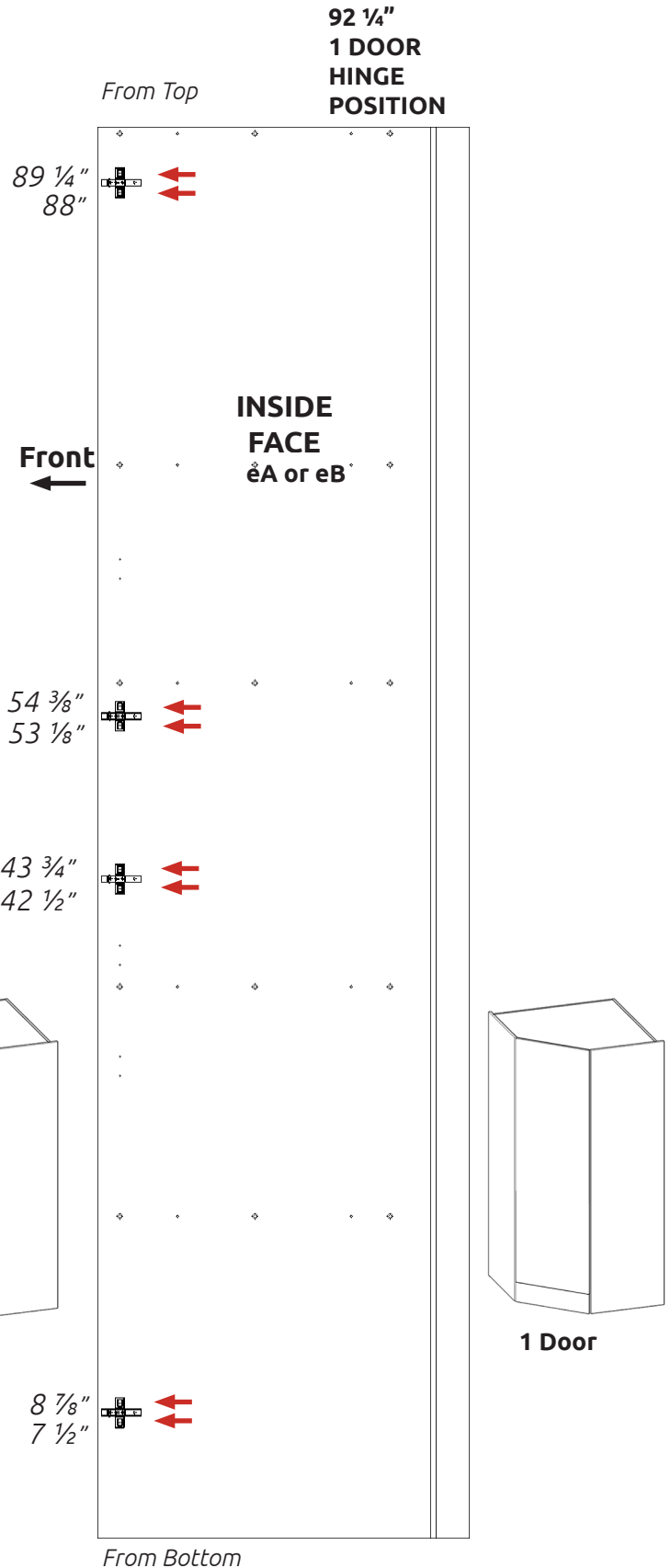
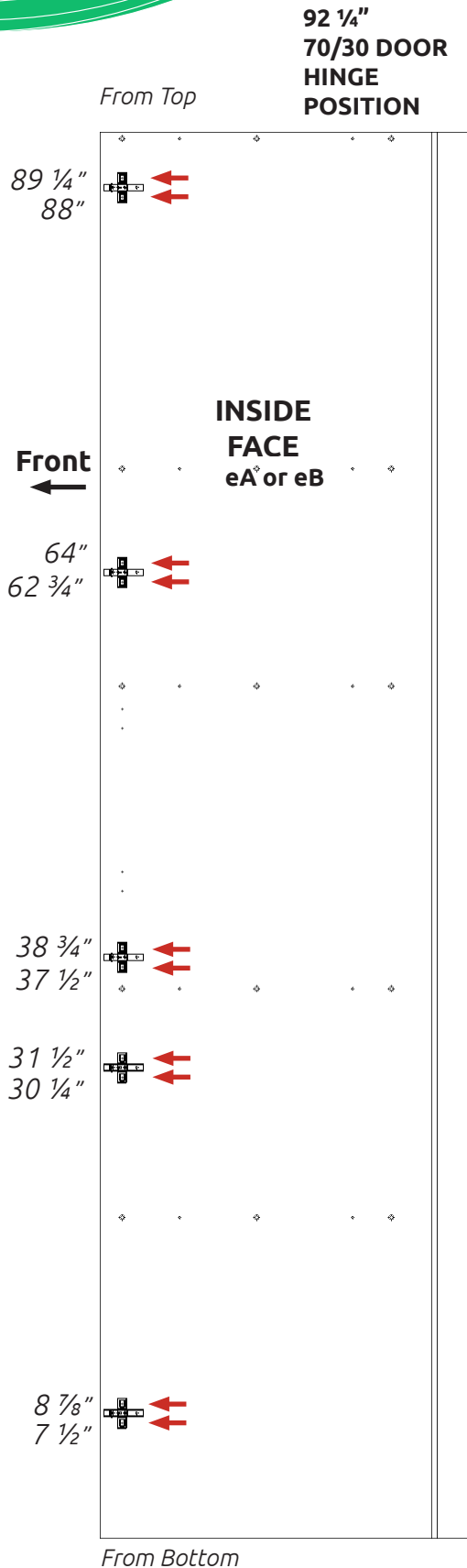

TOWER CABINET

84", 86 1/4", 92 1/4" & 98 1/4"
Walk in

Assembly Guide

Step 20.

Attach hinge plates onto end panels (**eA**) or (**eB**) to suit as shown.

Hinge side to be mounted in accordance to customer specific kitchen plan.

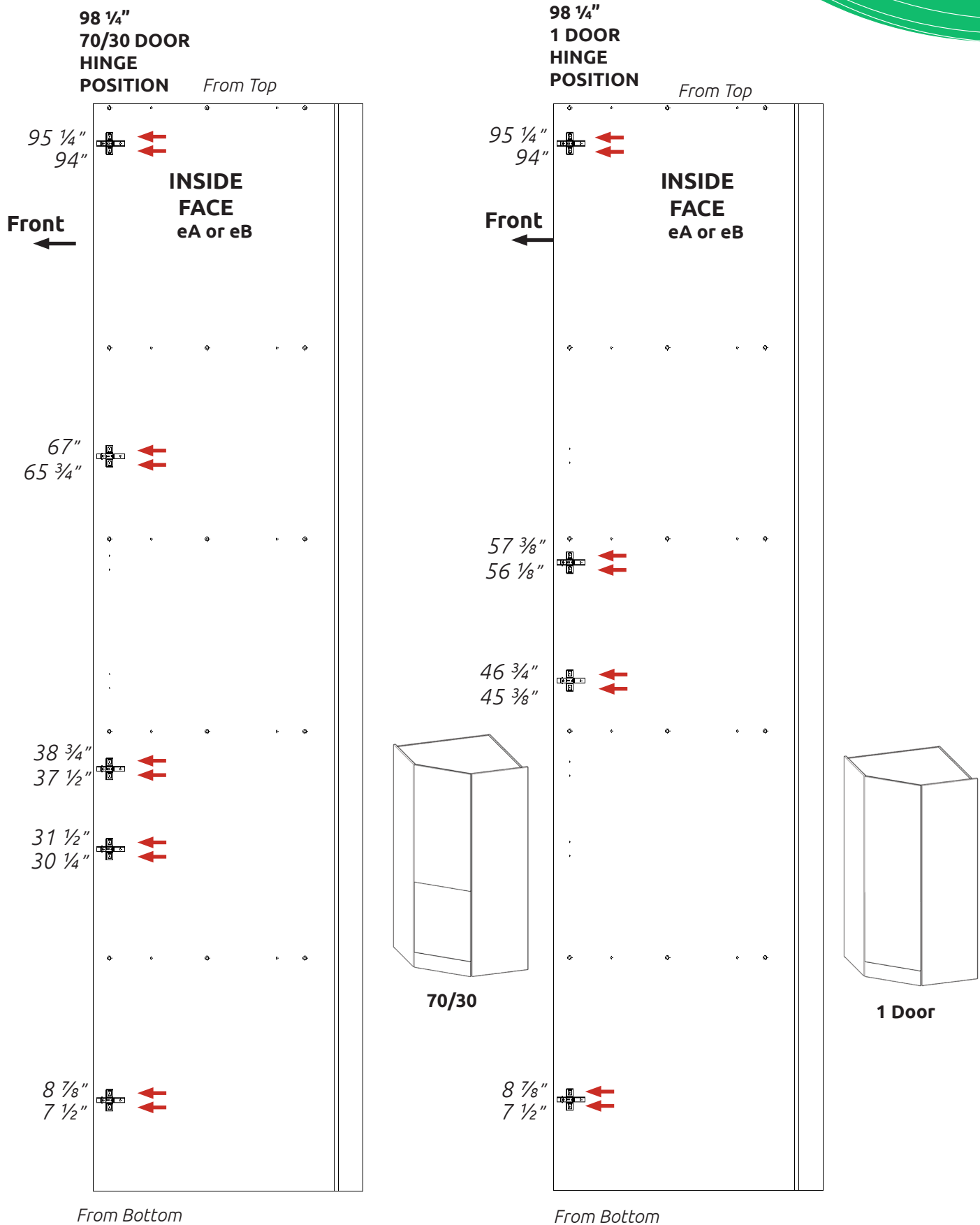

TOWER CABINET

84", 86 1/4", 92 1/4" & 98 1/4"
Walk in

Assembly Guide

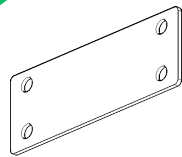

Fixing plates

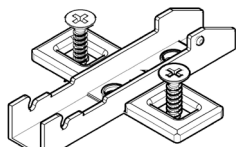
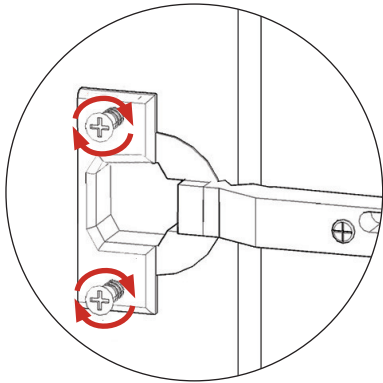

Hinge Plates

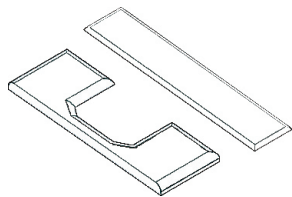

Hinge Cover Caps

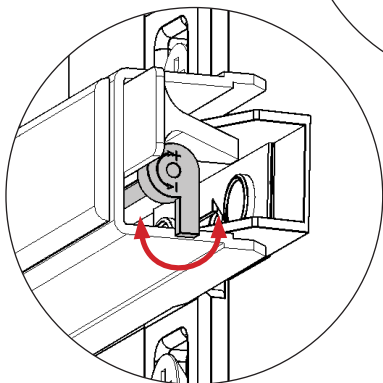
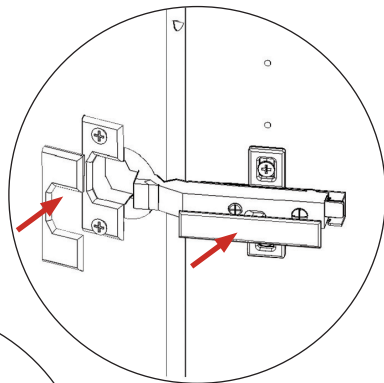

Soft-Close adjustment

Step 26.
Fit cover caps to hinge.
Adjust soft-close to suit.

The Top and Bottom hinges **MUST** be adjusted to the **SAME STRENGTH**.

Infinity + Hinge See Customer Specific Kitchen Plan

Step 21.
Insert hinge where required in holes as shown.

Step 22.
Align doors to join together using 2 x fixing plates (**Ff**) to the back of both frontals ensure a 1/8" gap is maintained between each frontal once fixed together.
Screw in place using 4 x 5/8" screws (**B**) per fixing plate.

Step 23.
Secure hinges by tightening 2 x screws with hinge dowels attached. These are already positioned within the hinges.

Step 24.
Attach the door to cabinet, clip hinge onto hinge plate and click to secure.

Step 25.
Adjust hinge to suit. As shown below.

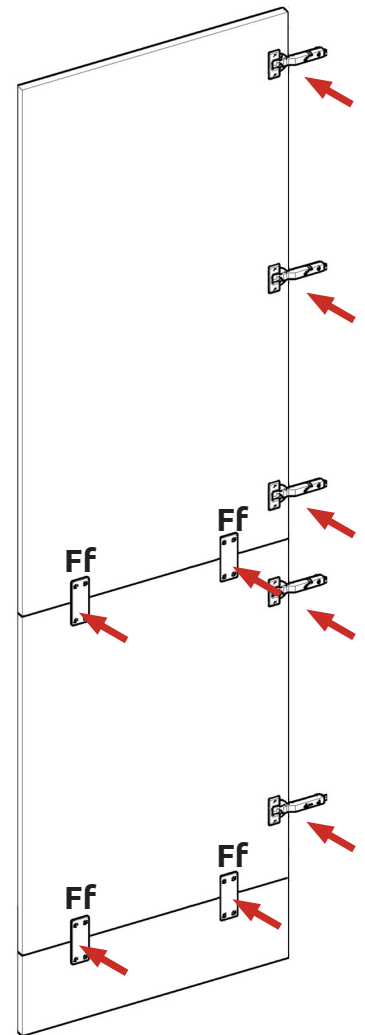

FRONTAL HINGE ADJUSTMENT

To **adjust** hinge using a screw driver, tighten or loosen as required at points **1 & 2**.
Point **1** - In - Out
Point **2** - Left - Right

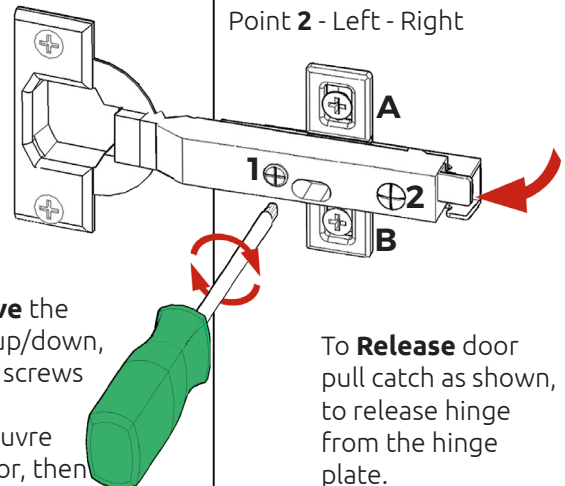

To **Move** the hinge up/down, loosen screws A + B, Manoeuvre the door, then re-tighten the screws

To **Release** door pull catch as shown, to release hinge from the hinge plate.

View from Inside of Carcase

TOWER CABINET

84", 86 1/4", 92 1/4" & 98 1/4"
Walk in

Assembly Guide

Infinity Hinge

See Customer Specific Kitchen Plan

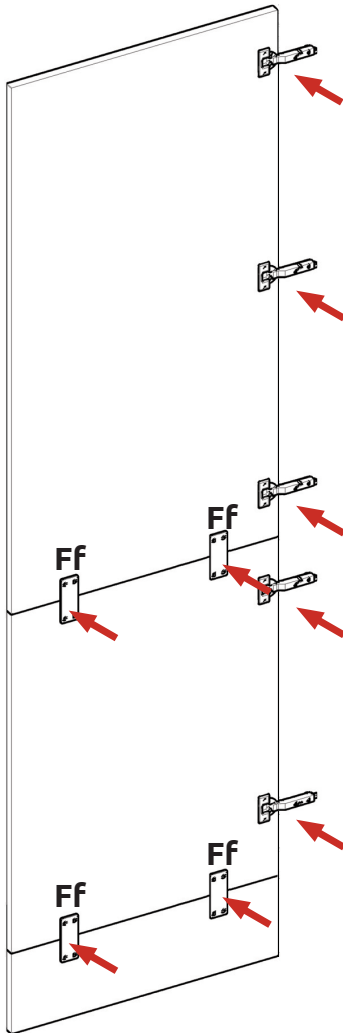

Step 21.

Insert hinge where required in holes as shown.

Step 22.

Align doors to join together using 2 x fixing plates (FF) to the back of both frontals ensure a 1/8" gap is maintained between each frontal once fixed together. Screw in place using 4 x 5/8" screws (B) per fixing plate.

Step 23.

Secure hinges by tightening 2 x screws with hinge dowels attached. These are already positioned within the hinges.

Step 24.

Attach the door to cabinet, clip hinge onto hinge plate and click to secure.

Step 25.

Adjust hinge to suit. As shown below.

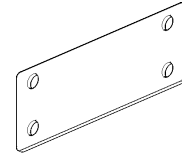

Fixing plates

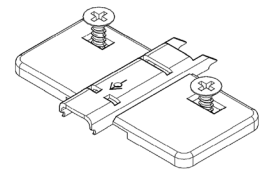
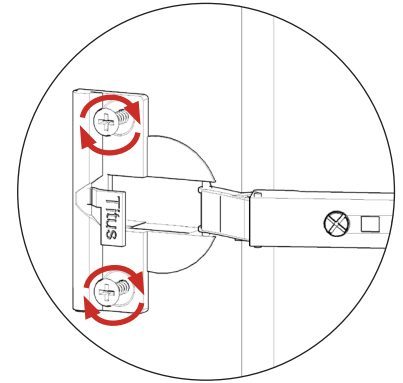

Hinge Plates

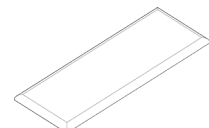

Hinge Cover Caps

Step 26.

Fit cover caps to hinge. Adjust soft-close to suit.

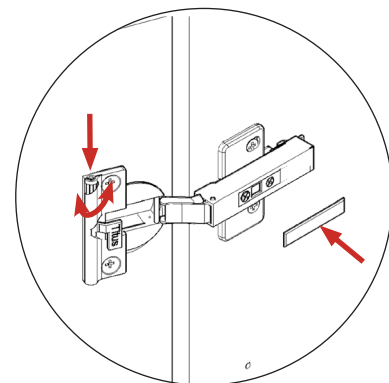

FRONTAL HINGE ADJUSTMENT

To **adjust** hinge using a screw driver, tighten or loosen as required at points 1 & 2.
Point 1 - In - Out
Point 2 - Left - Right

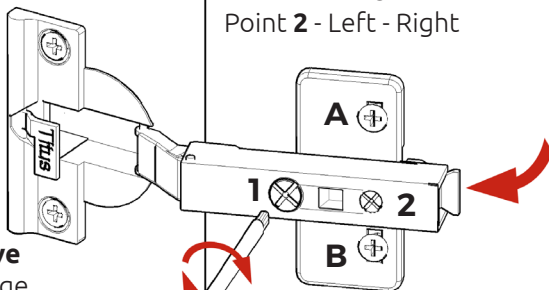

To **Move** the hinge up/down, loosen screws A + B, manoeuvre the door, then re-tighten the screws

To **Release** door pull catch as shown, doing so will release the hinge from the hinge mounting plate.

View from Inside of Carcase

The Top and Bottom hinges **MUST** be adjusted to the **SAME STRENGTH.**

TOWER CABINET

84", 86 1/4", 92 1/4" & 98 1/4"

Walk in

Assembly Guide

TOWER CABINET

84", 86 1/4", 92 1/4" & 98 1/4"
Walk in

Assembly Guide

