

TOWER CABINET

Milano Appliance
Housing Fixing

Assembly Guide

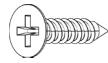

(B) 5/8" Screws

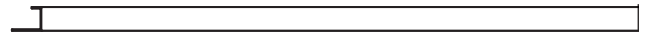

(Hf) 2 x 78" Housing Fixing

Step 1.

Measure the height of the appliance then measure and cut the housing fixing **(Hf)** to the required length. Repeat for both sides. Ensure it is cut straight so it sits flush with the appliance. If both lengths cannot be obtained from one housing fixing (Option 1), mark one length per fixing (Option 2).

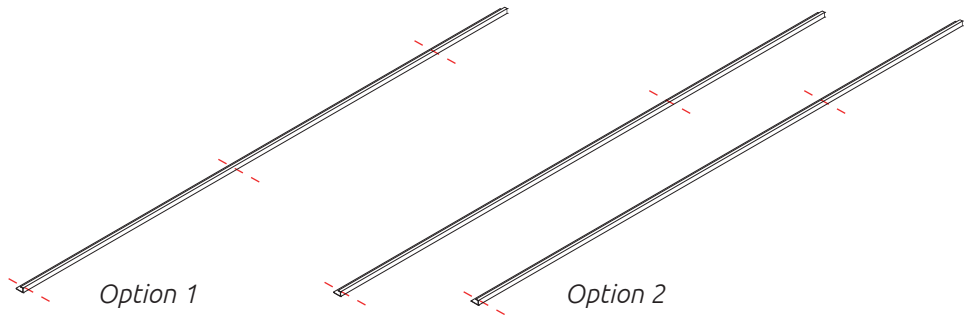
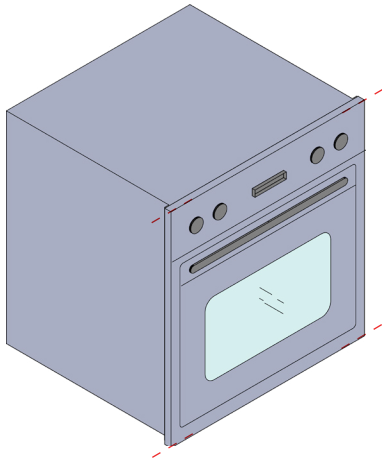

Step 2.

Wrap housing fixing **(Hf)** around the milano profile with the widest face directed inwards. Pre-drill 3/16" countersunk holes 3/8" from the back of the housing fixing and 1 15/16" from the top and bottom edges. Add additional 3/16" countersunk holes every 15 3/4" if required.

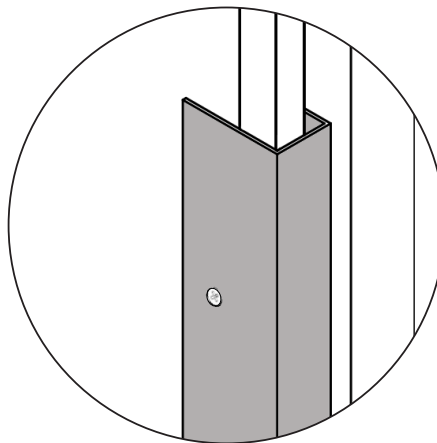
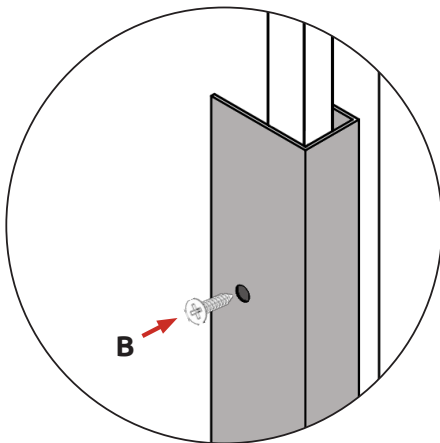
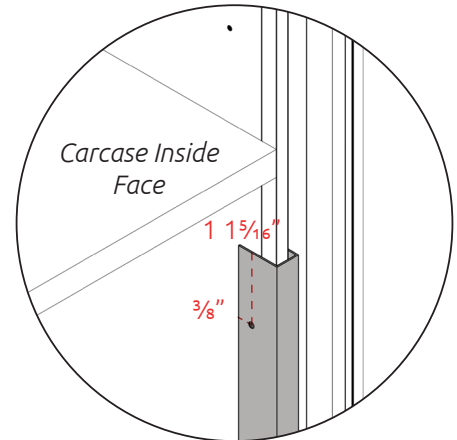

Step 3.

Use 5/8" screws **(B)** to attach the housing fixing to the cabinet.

REQUIRED TOOLS



NOT to be
used with
CAM DOWEL
& CAM LOCK

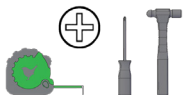

wren
KITCHENS

TOWER CABINET

Milano Appliance
Housing Fixing

Assembly Guide

Step 4.

Insert the appliance into the cabinet.

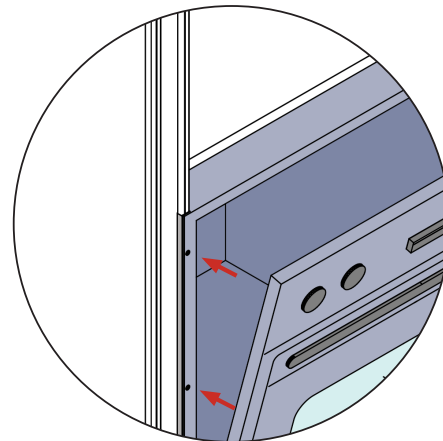
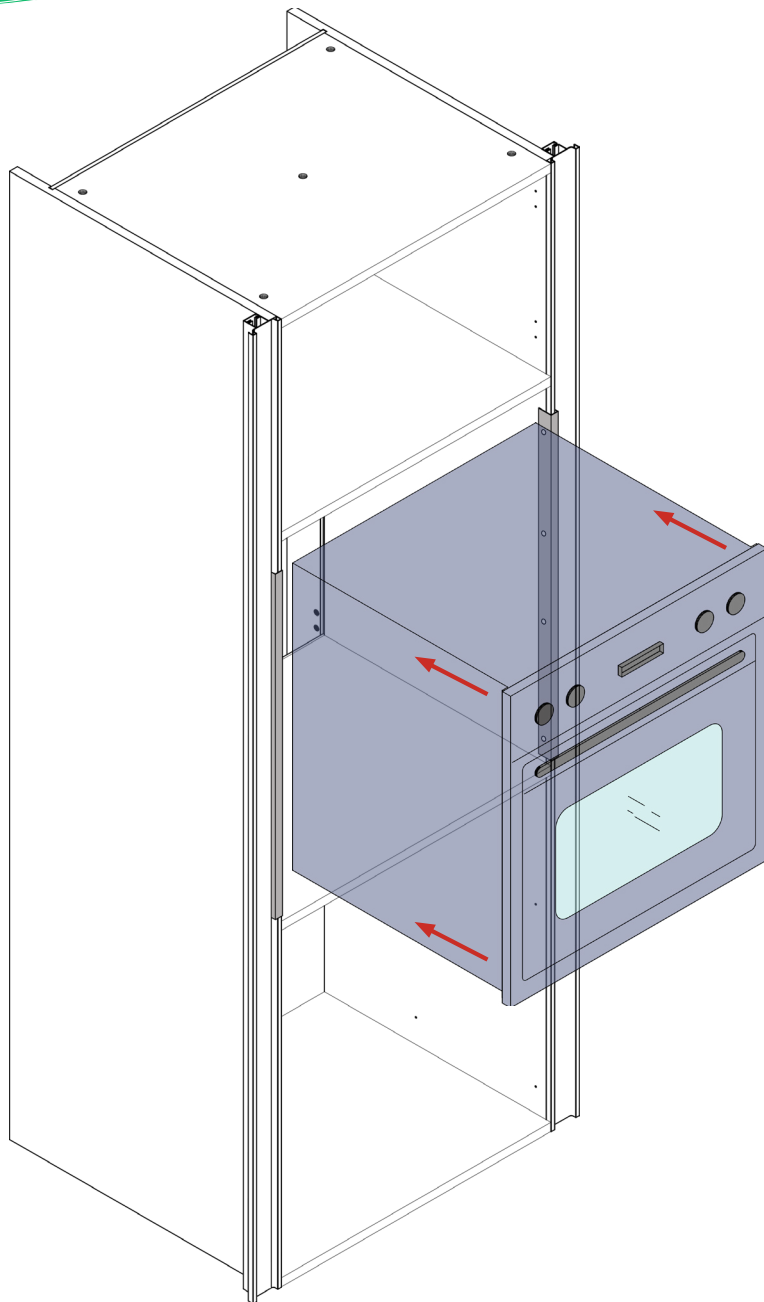

Step 5.

Open the appliance to reveal its frame and expose the holes on each side. Using those holes as a guide, drill pilot holes into the fixing, using appropriate sized drill bits.

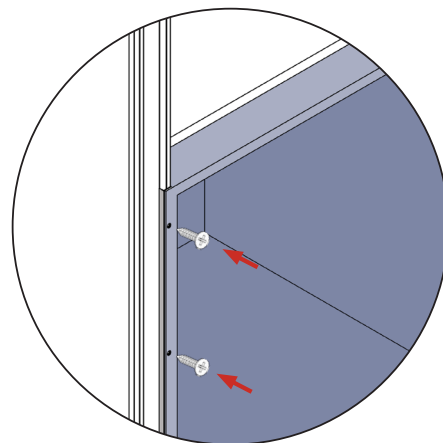

Oven 2DR 2Drw Used as an Example

Step 6.

Secure the appliance to the housing fixing using appropriate screws.

TOWER CABINET

Milano Appliance
Housing Fixing
Assembly Guide

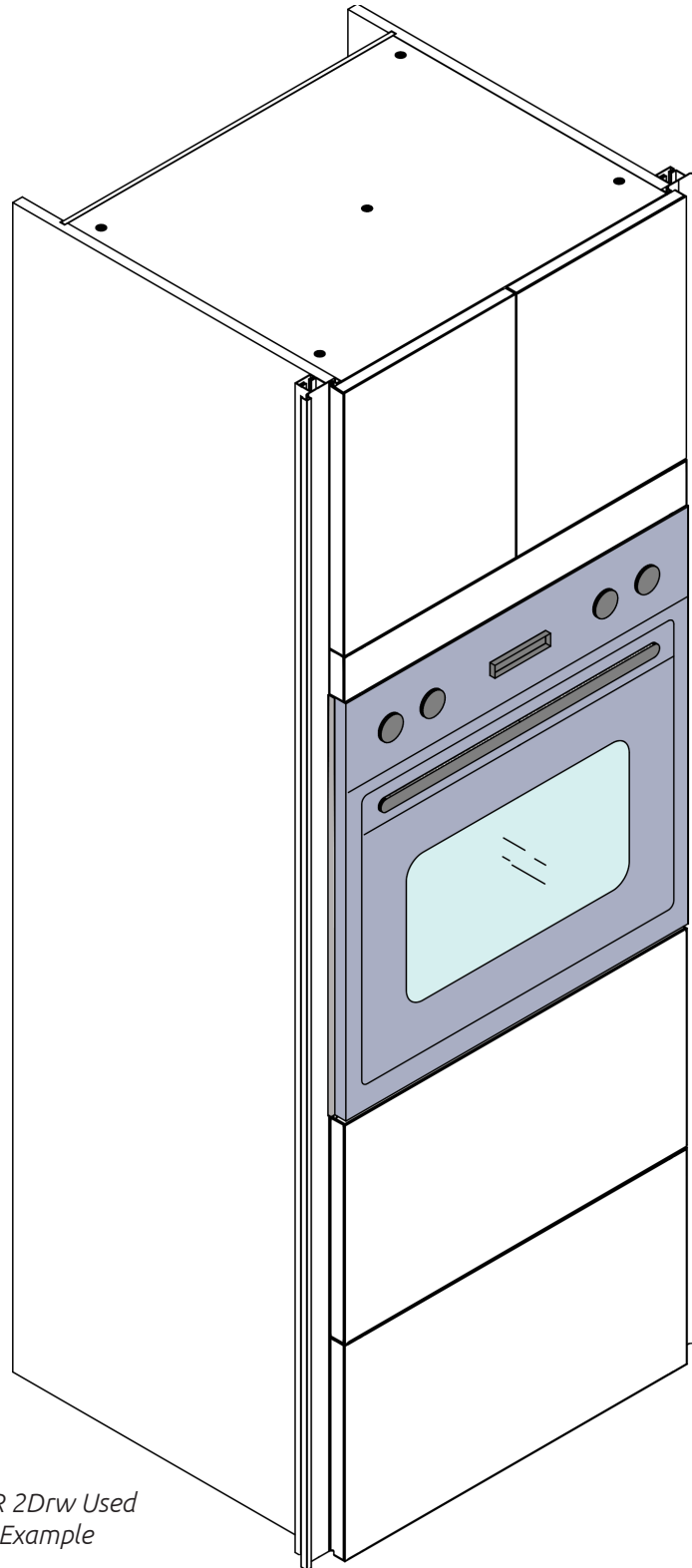

*Oven 2DR 2Drw Used
as an Example*

wren
KITCHENS