

## FITTING GUIDE

### BASE CABINET

HEIGHT: 19 1/2" - 34 1/2"

WIDTH: 6" - 27"

DEPTH: 13 1/2"

## FI.PK.FIT.018 - BASE 6

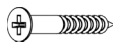

(H) x8 1 1/4"  
Screws



(B) x32 5/8"  
Screws



Screws for attaching to walls and countertop are not provided as these vary depending on materials, thickness and construction. Ensure appropriate fixings for wall and countertop construction are used. Please refer to the specialist countertop supplier if these are required for solid surface countertops.

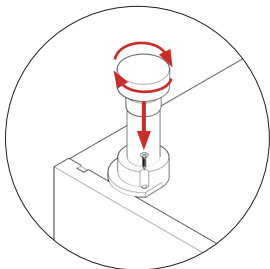

#### Step 1.

Secure each leg into place with 2 x 5/8" screws (B). Ensure legs are rotated as shown so that end panel is supported.

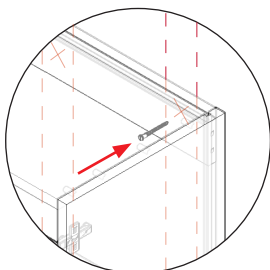

View cut away from top panel.

#### Step 3.

Position cabinet and screw in two places in the top hanging rails. Where possible screw into a stud to secure the cabinet to the wall.

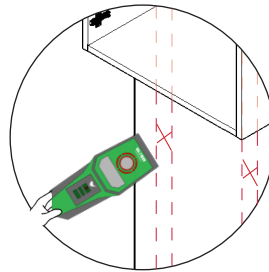

#### Step 4.

If a stud is not available secure to wall using suitable fixings and screw into adjacent cabinets as in step 5.

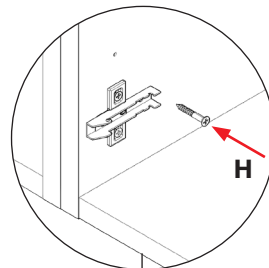

Sample Hinge Shown

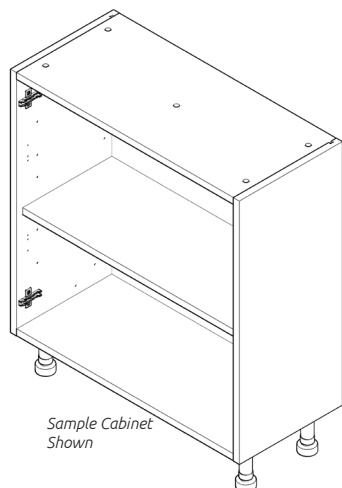

Sample Cabinet Shown

#### Step 5.

Screw into any adjacent cabinets using 1 1/4" screws (H) provided to secure the cabinet. Screw just to the rear of the hinge plate and to the rear of the cabinet at the top and bottom. Place cover caps on the screw heads to conceal them.

#### Step 6.

Screw up through the top of the cabinet into the countertop to secure it in place.

**wren**  
KITCHENS