

INDUSTRIAL

Assembly Guide

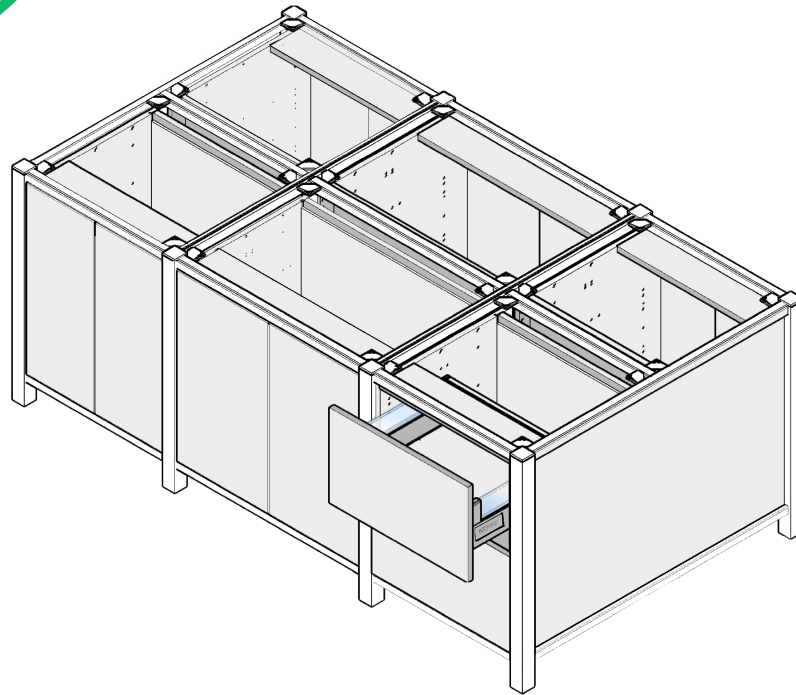

ISLAND

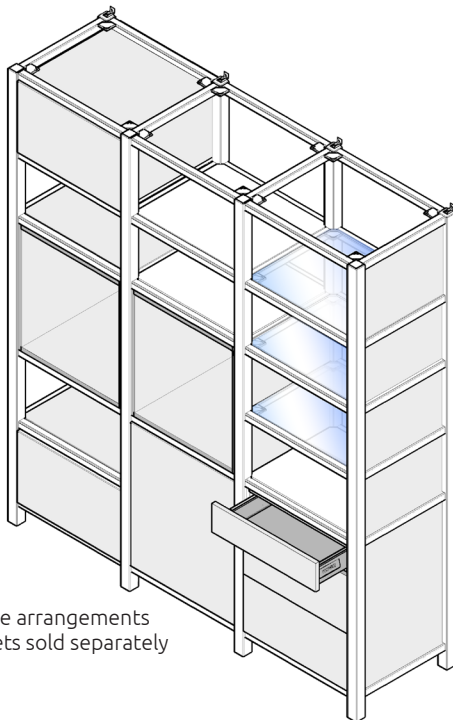

Sample arrangements
cabinets sold separately

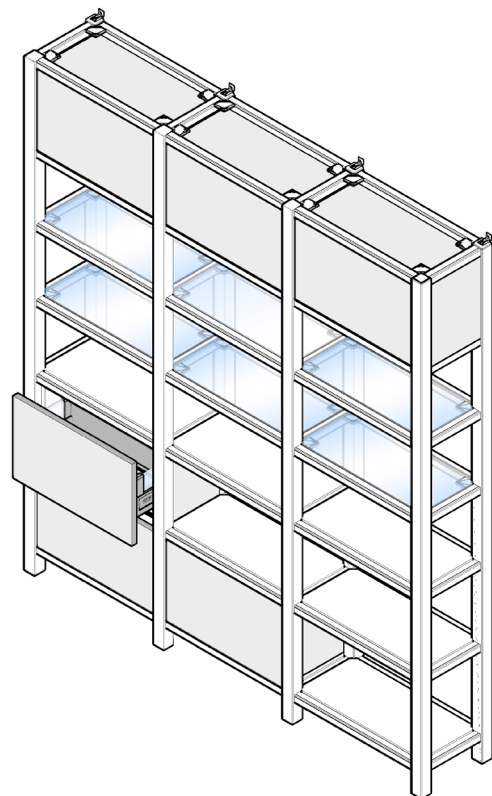

TOWER



INDUSTRIAL

Assembly Guide

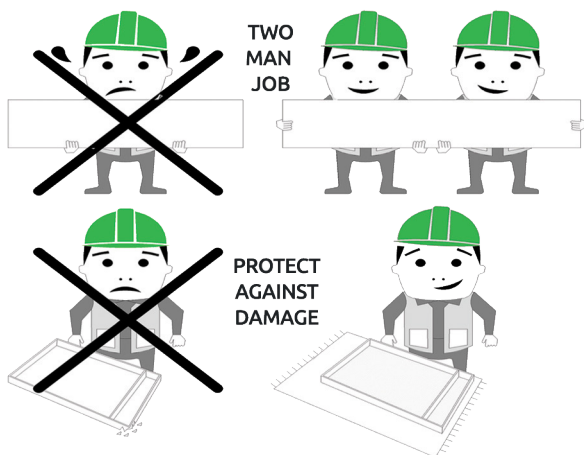

INSTALLATION SHOULD BE PERFORMED BY A COMPETENT PERSON ONLY. THIS PRODUCT COULD BE DANGEROUS IF INCORRECTLY INSTALLED.

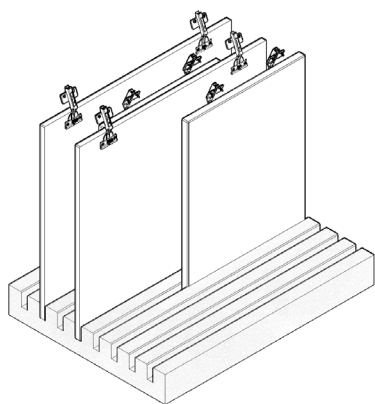

DOORSAFE

PRIOR TO INSTALLATION, FIXTURES INCLUDING DOORS, DRAWERS, LOOSE SHELVES & LEGS SHOULD BE REMOVED TO ENSURE A SAFE INSTALLATION. WREN RECOMMENDS USING DOORSAFE FOR TEMPORARY STORAGE.

REQUIRED TOOLS

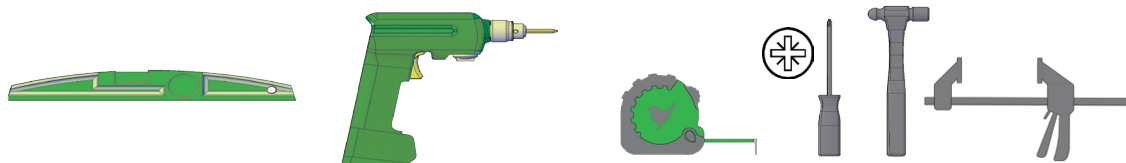

INDUSTRIAL TOWER

Assembly Guide

End Components



Legs

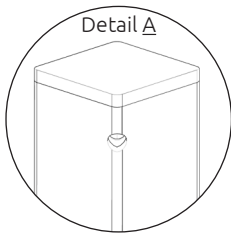

Detail A

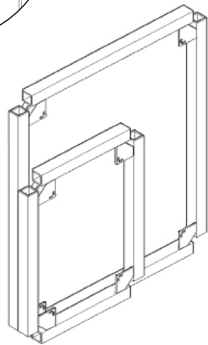

(13 3/4" x 27 1/4")
(24 5/16" x 33 1/4")
End Frame Shelving

Extension Components

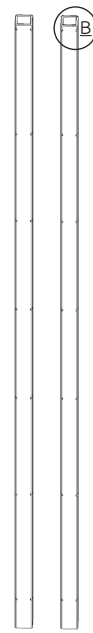

Legs

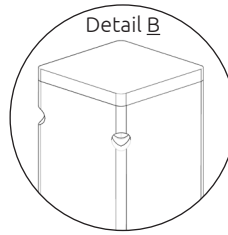

Detail B

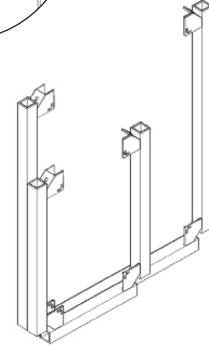

(13 3/4" x 24 1/8")
(24 5/16" x 30 1/16")
Extension Frame Shelving

Configuration may vary in accordance to customer specific kitchen plan.
cabinets provided separately.



(J)
5/8"
Screw



(H)
1 1/4"
Screw

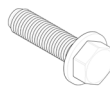

1 3/8" Bolt
& Washer



5/8" Bolt
& Washer

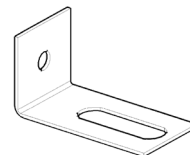

Wall Securing
Bracket

INDUSTRIAL TOWER

Assembly Guide

Tower Frame Assembly

Step 1.

Using 4 x 1 3/8" bolts & washers attach end frame shelf to end or internal legs, as shown.

Adjust leg height per frame by twisting bottom feet to suit.

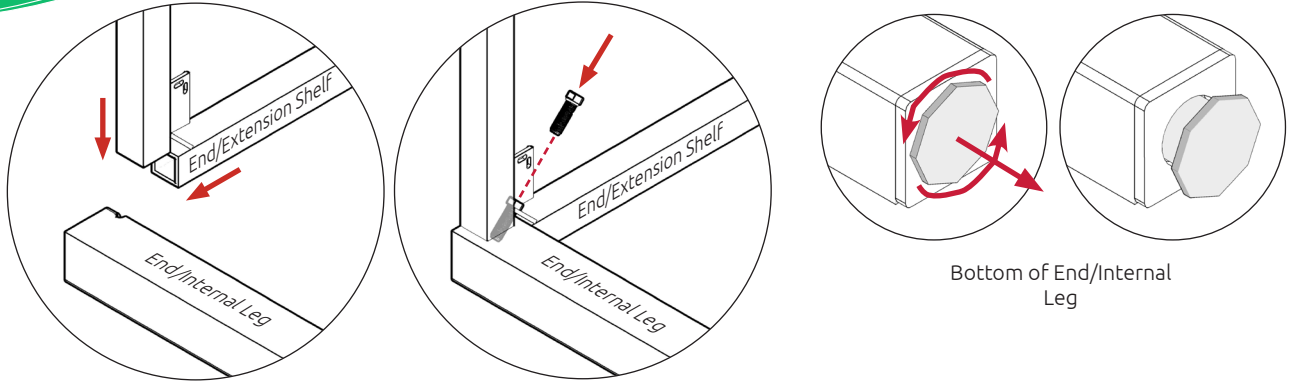

Step 2.

Repeat shelf assembly as appropriate, to form end/extension tower frame, as shown.

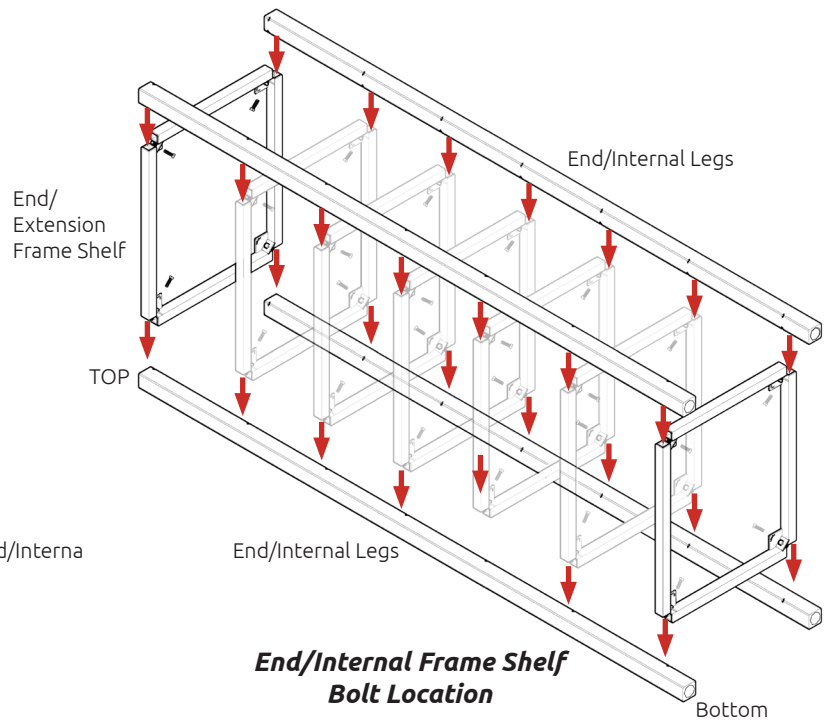
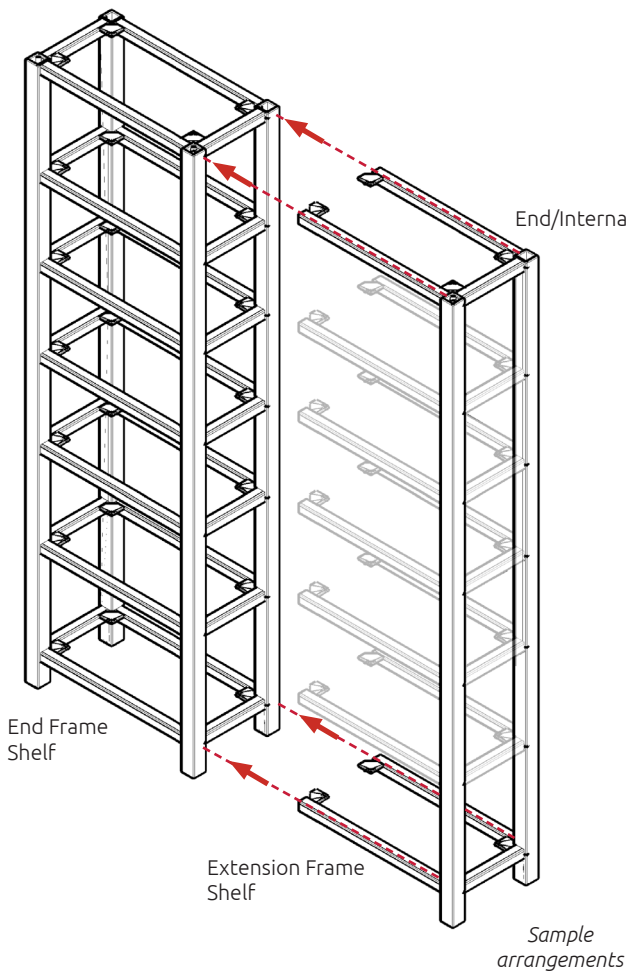

Step 3.

Attach assembled tower frames where appropriate, subject to kitchen requirements as shown.

Tower Assembly

See Customer Specific Order for requirements.



Please ensure steps are followed for a safe installation.

INDUSTRIAL TOWER Assembly Guide

Step 4. Securing Metal Frame to Wall

To secure tower frames, use the provided brackets to secure to wall. Secure bracket to the top of end leg caps at both sides using a 5/8" bolt & washer. Then screw through into wall as shown.

Screws for fixing to walls are not provided as these vary depending on your wall material and construction. Ensure appropriate fixings for wall constructions are used.

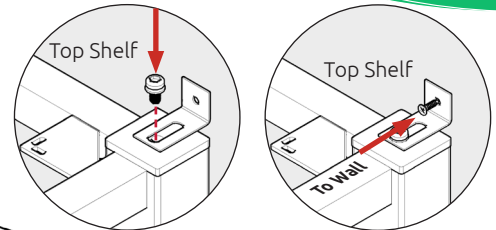

Step 5. Cabinet Installation

Where applicable, position door and drawer cabinets in accordance to specific frontal thickness.

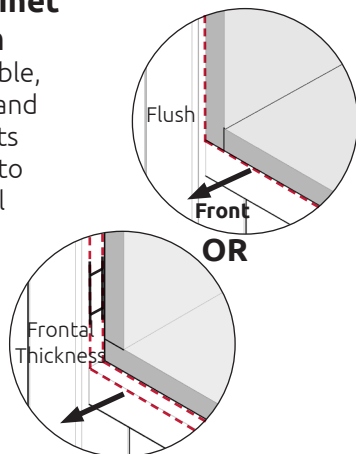

Step 6.

Using 2 x 5/8" screws (B) per connecting plate, screw up through fixing plate into the base panel of each cabinet as shown.

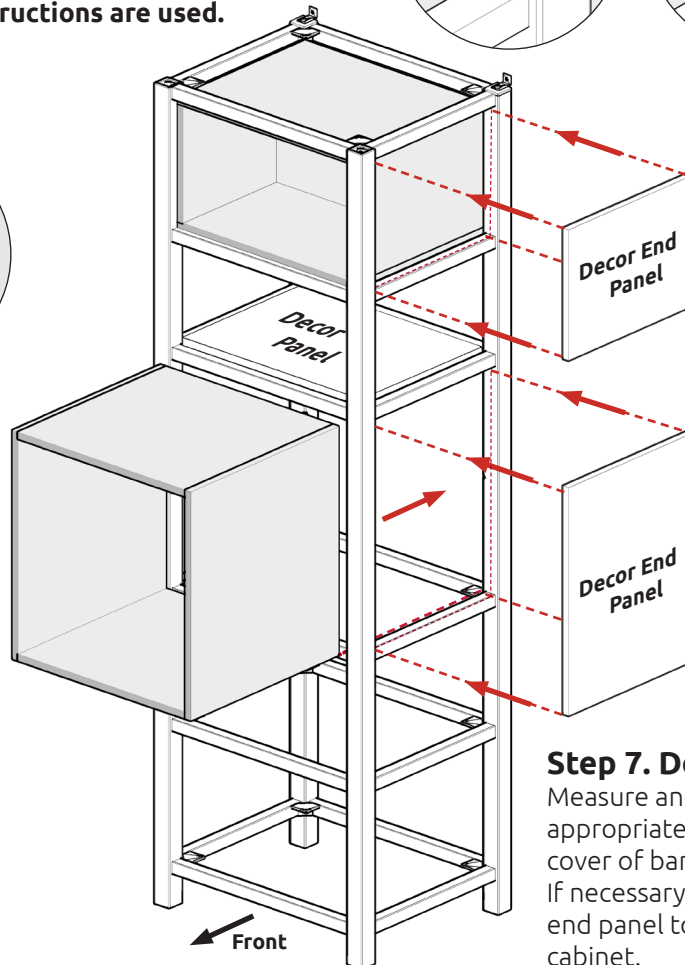
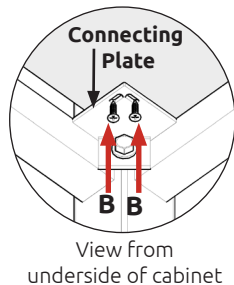

Step 7. Decor Panels

Measure and cut appropriately to ensure full cover of bare carcass. If necessary, scribe decor end panel to end of cabinet.

Step 8. Decor Panel Installation

Ensure cabinets are located as per customer specific plan. Clamp decor end panels adjacent to the cabinet inside of the frame and screw through the cabinet into the decor panel using 1 1/4" screws (H). Screw at the top and bottom of cabinet away from fixings such as drawer runners and hinges. For upper decor panels screw through the top of the cabinet at the front/back.

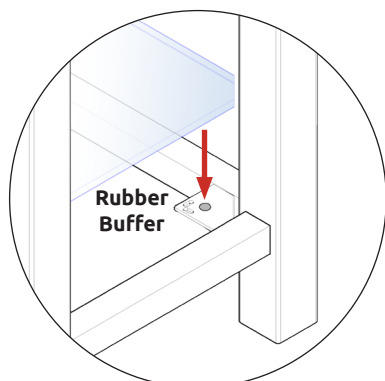

Step 9. Glass Shelf Installation

For glass shelf installation only, install 1x rubber buffer provided with glass shelf, on each connecting plate as shown. **Position glass shelf with care.**

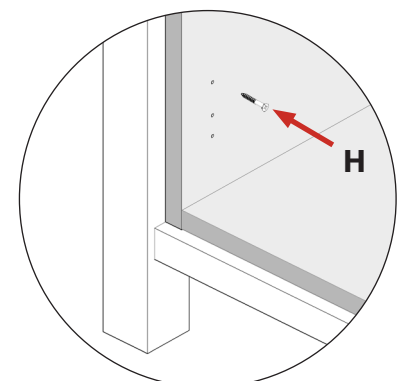

INDUSTRIAL ISLAND

Assembly Guide

End Components:

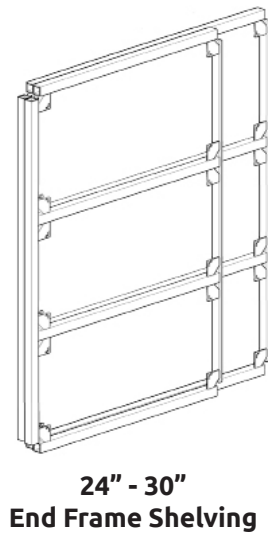
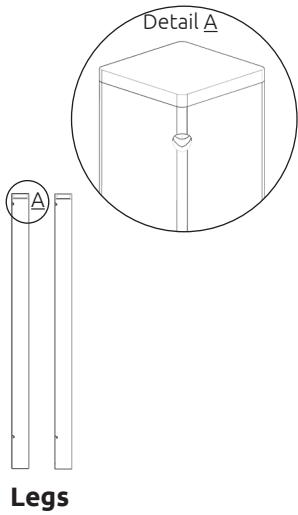

Internal Components:

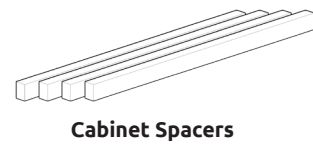
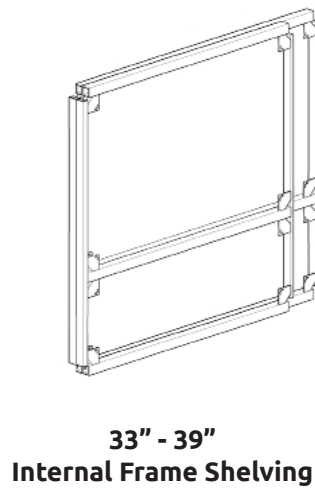
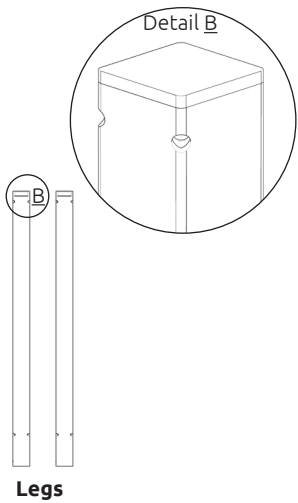

Configuration may vary in accordance to customer specific kitchen plan

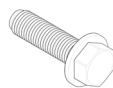

Island Frame Assembly

INDUSTRIAL ISLAND

Assembly Guide

Step 1.

Using 4 x 1 3/8" bolts & washers attach end frame shelf as shown, to secure to end or internal legs (where applicable). Adjust leg height per frame by twisting bottom feet to suit.

For Shelf Positions see Customer Specific Kitchen Plan.

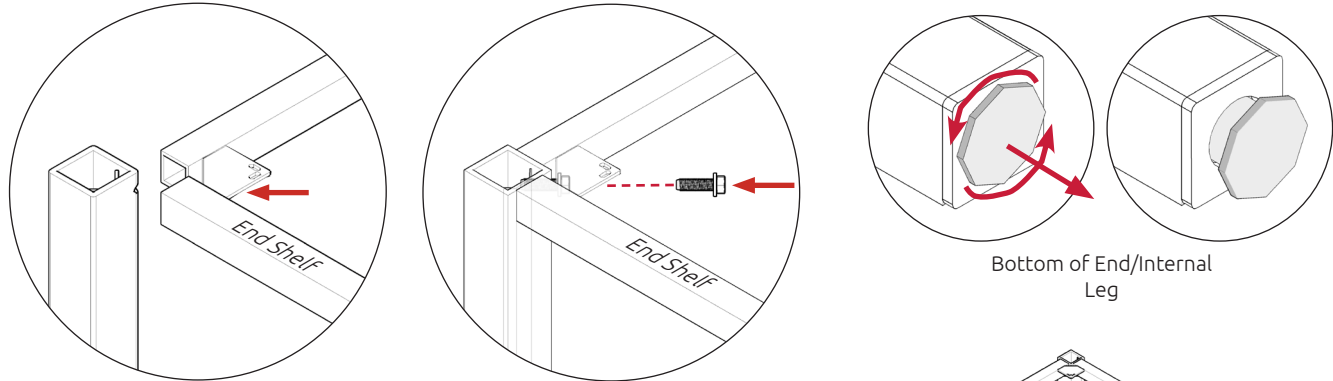

Step 2.

Using 4 x 1 3/8" bolts & washers secure internal frame shelf to internal legs as shown where applicable.

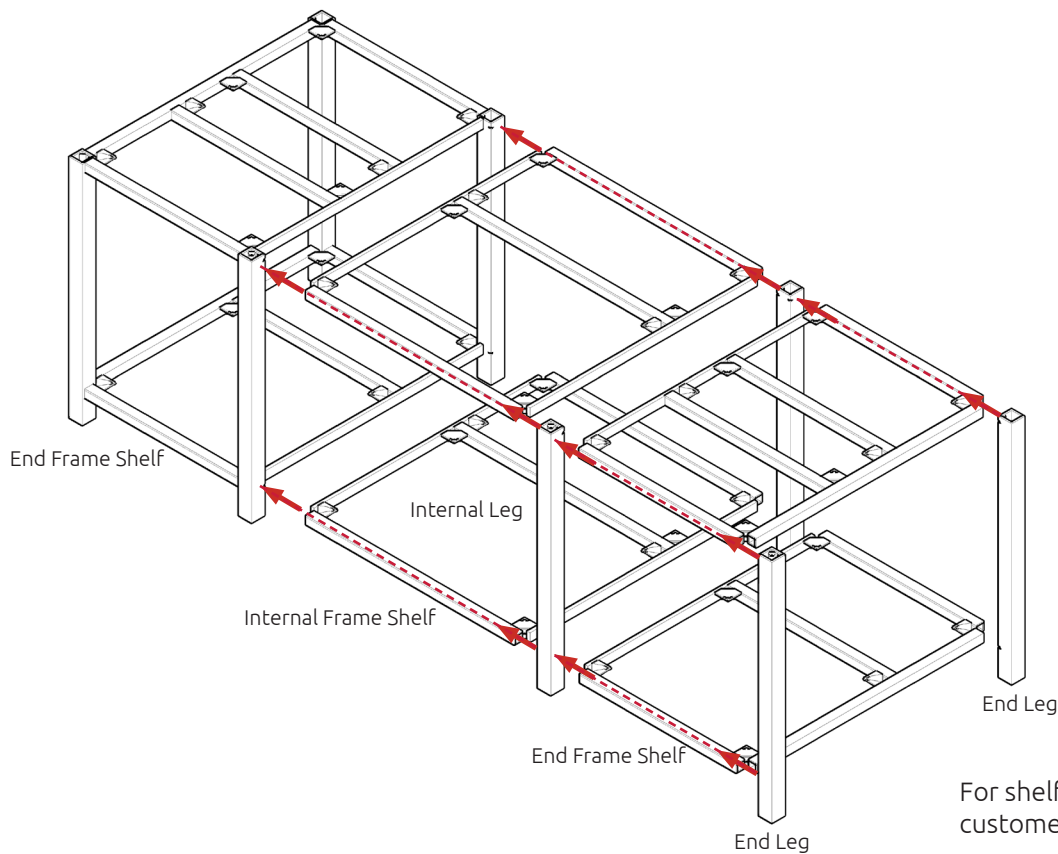
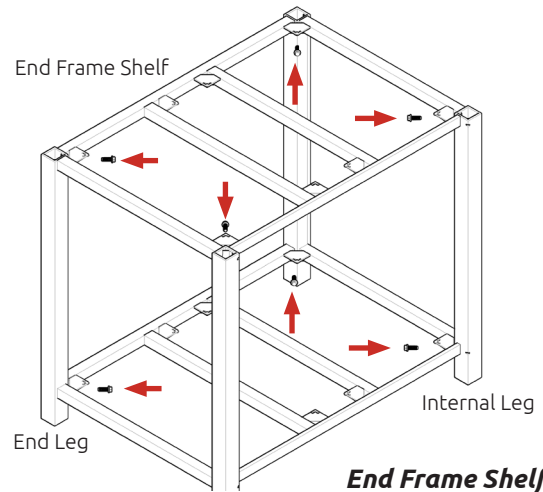

For shelf positions refer to customer specific kitchen plan.

INDUSTRIAL ISLAND

Assembly Guide

Island Assembly

See Customer Specific order for requirements.



Please ensure steps are followed for a safe installation.

Step 3. Countertop Installation

To secure countertop, screw up through connecting plates into your countertop to secure it in place.

Screws for attaching to countertop are not provided as these vary depending on materials, thickness and construction.

Ensure appropriate fixings for countertop construction are used. Please refer to the specialist countertop supplier if these are required for solid surface countertops.

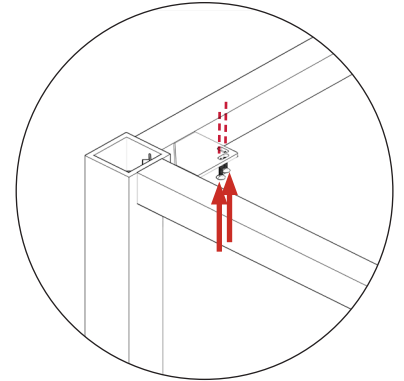

Step 4. Cabinet Installation

Where applicable, position door and drawer cabinets in accordance to frontal thickness. Measure and cut provided spacer panel appropriately. Position flush against internal cabinets at both sides, as shown. Ensure correct positioning of cabinets.

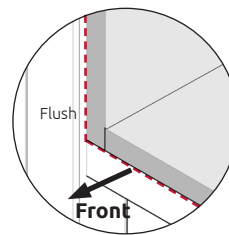
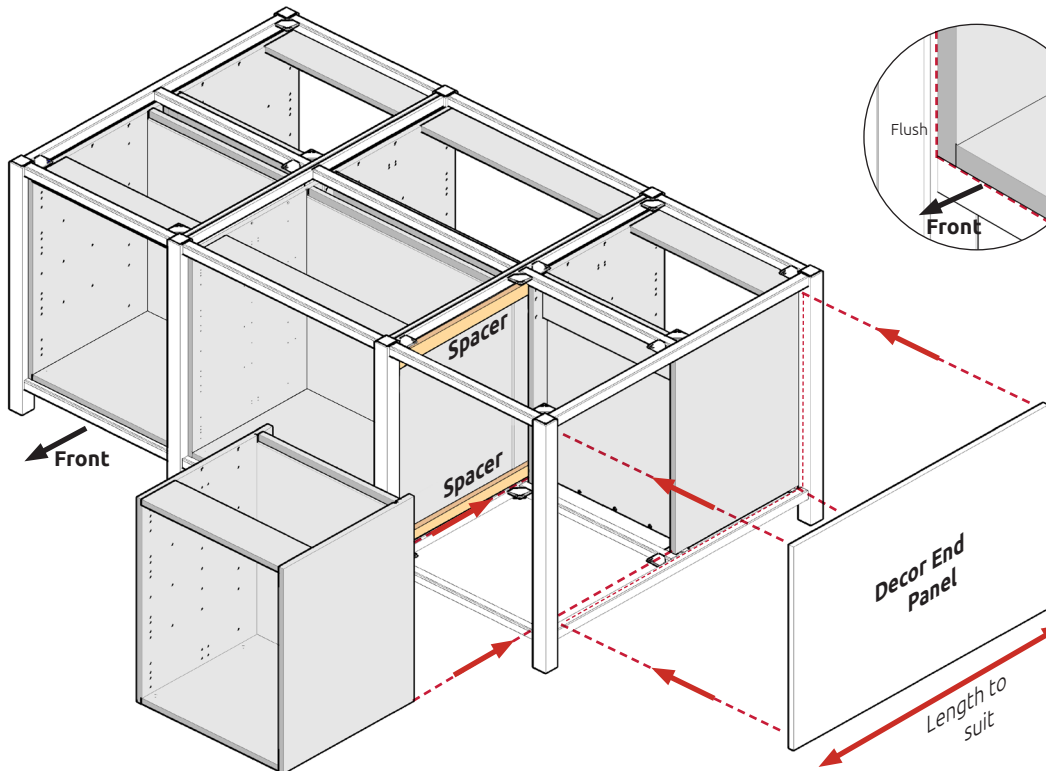

OR

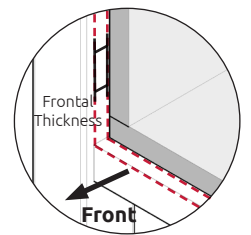

Step 5. Decor Panel Installation

Measure and cut appropriately to ensure full cover of bare carcass. Where required, scribe decor end panel to the end of cabinet. Clamp decor end panel adjacent to the cabinet within the frame.

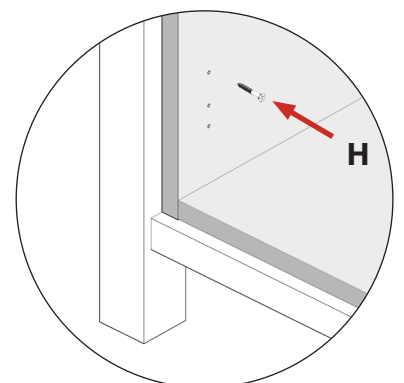

Step 6. Cabinet Securing using Spacer/Decor Panel

Ensure cabinets are located accordingly. Screw through cabinet into spacer/decor end panel using 1 1/4" screws (H) provided. Screw as shown at top and bottom of cabinet, away from fittings.

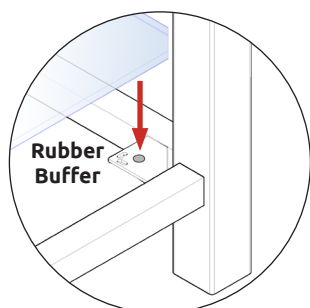

Step 7. Glass Shelf Installation

For glass shelf installation only, install 1x rubber buffer provided with glass shelf, on each connecting plate as shown.

Position glass shelf with care.