

FRONTÄLS

BUILT UNDER OVEN
HOUSING FILLER

Attachment Guide

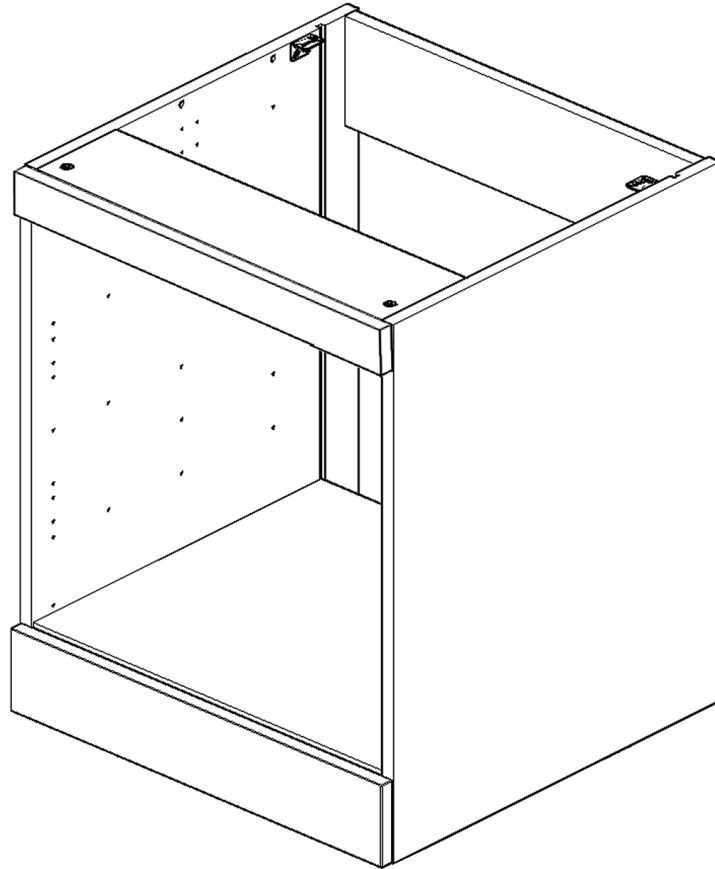

FILLER

FRONTALS

BUILT UNDER OVEN HOUSING FILLER

Attachment Guide

Step 1.

Secure L bracket SML (**J**) onto the inside face of the Top Filler, $1\frac{1}{16}$ " from the side edges and $\frac{15}{16}$ " from the top edge of the filler as shown below, using 2 x $\frac{5}{8}$ " screws (**B**). Align so filler is in line with adjacent frontals.

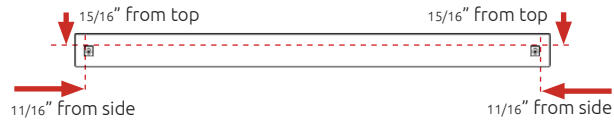

Step 2.

Secure the top filler with L bracket SML (**J**) to top of rail with 2 x $\frac{5}{8}$ " screws (**B**) as shown. **Ensure frontal is in line with adjacent units. Space appropriately from carcass.**

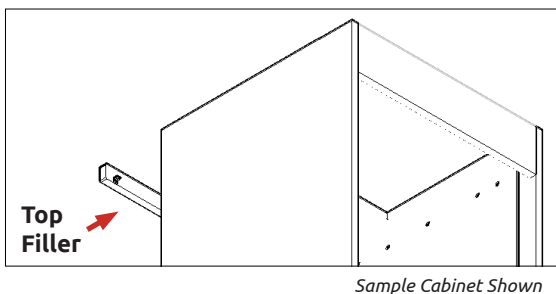
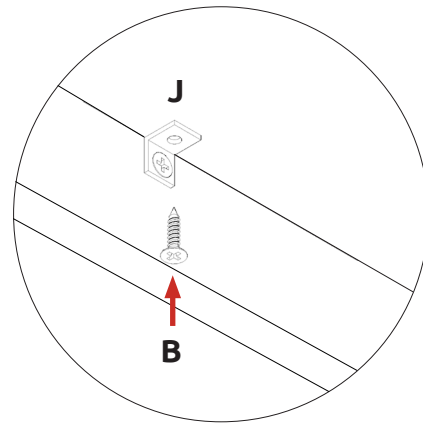
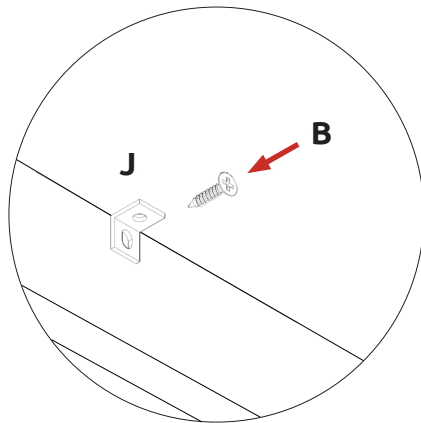

Step 3.

Secure both dummy fixing clip parts (**Rii**) onto the end panels using 2 x $\frac{5}{8}$ " screws (**B**) each, as shown. The centre hole is to be positioned $1\frac{15}{16}$ " from the bottom of the panel and $1\frac{3}{8}$ " from the front of the panel.

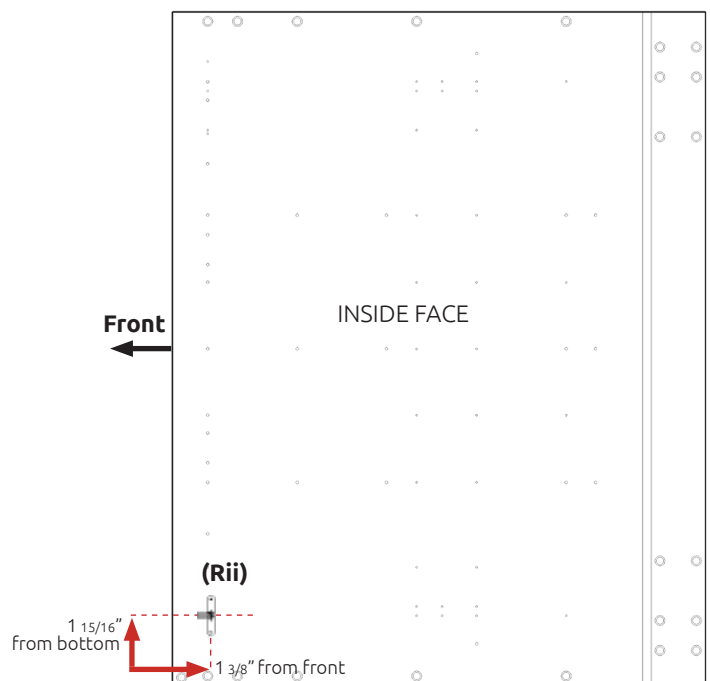

FRONTALS BUILT UNDER OVEN HOUSING FILLER

Attachment Guide

Step 4.

Secure dummy fixing clip **(Ri)** onto the inside face of the bottom filler, 1 1/8" from the side edges and 1 15/16" from the top edge, using 2x 13/16" screws **(G)**.

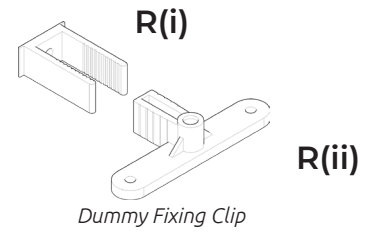
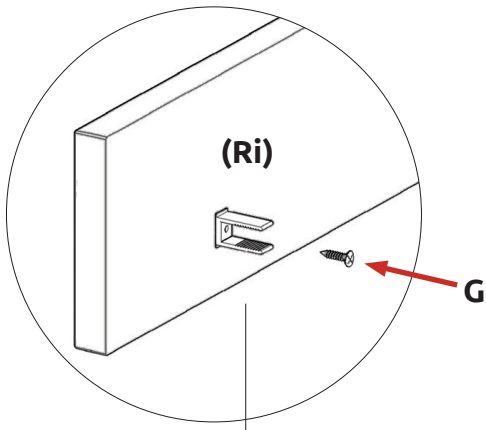

Step 5.

Align and push frontal into place until secure.

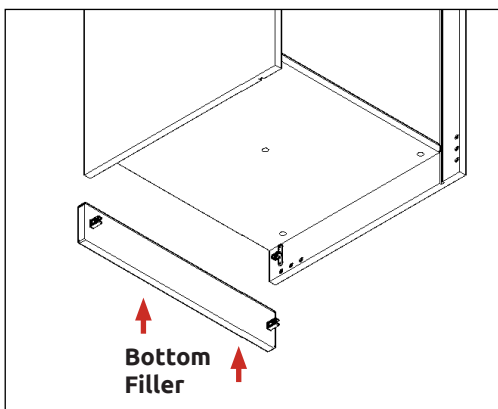
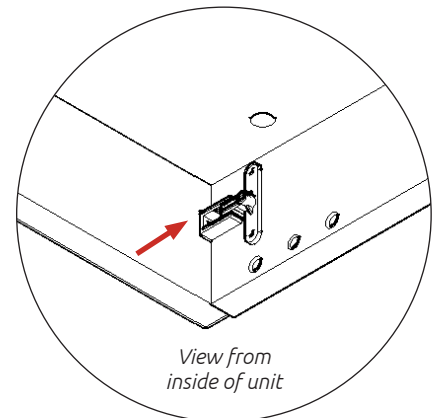

Sample Cabinet Shown

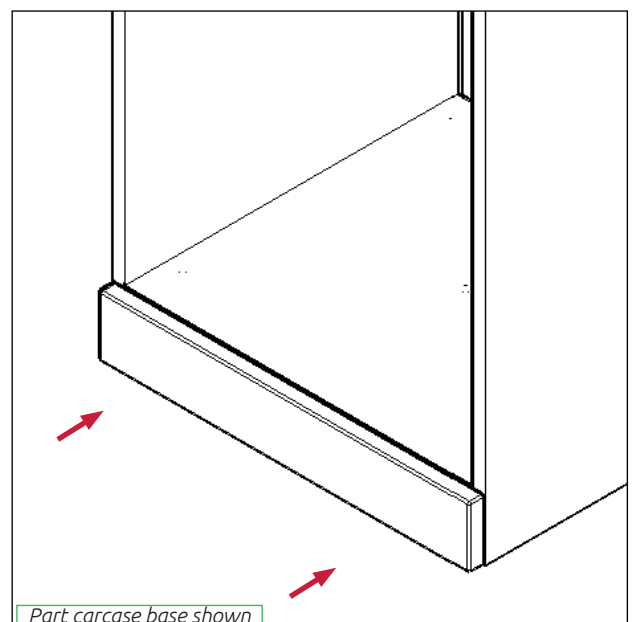

Part carcass base shown

wren
KITCHENS