

ACCESSORIES

Upstand Return Fitting Guide

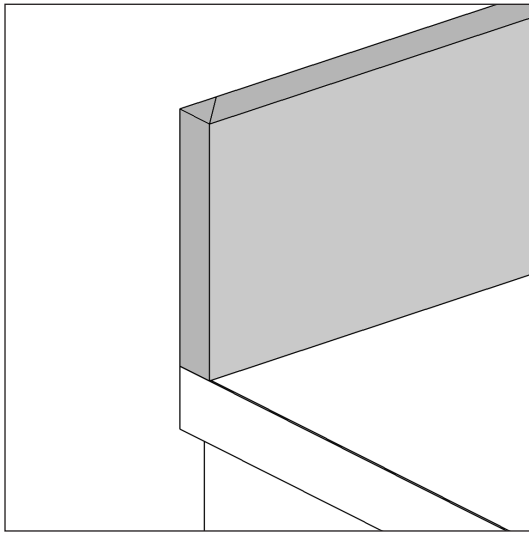

Upstand with return

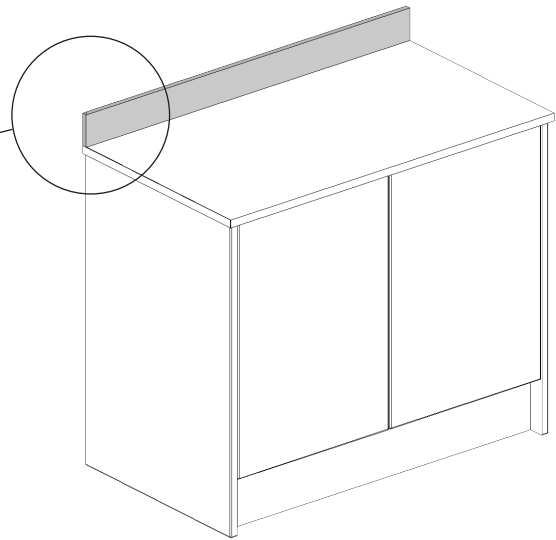

Example base unit with upstand for reference only

Measure length of worktop and cut upstand to size with a 45° mitre cut at the appropriate end, ensure the outer face of the mitre is the length of the worktop (see figure 1).

Cut a second piece of upstand with a 45° mitre cut in the opposite direction to make the end piece. The width of the end piece should be the same as the thickness of the upstand.

See cutting plan below, EP = Upstand end piece

Secure the end piece to the upstand using appropriate adhesive (see figure 2).

