

*Vogue*

# WALL UNIT

## 672 L Corner Assembly Guide

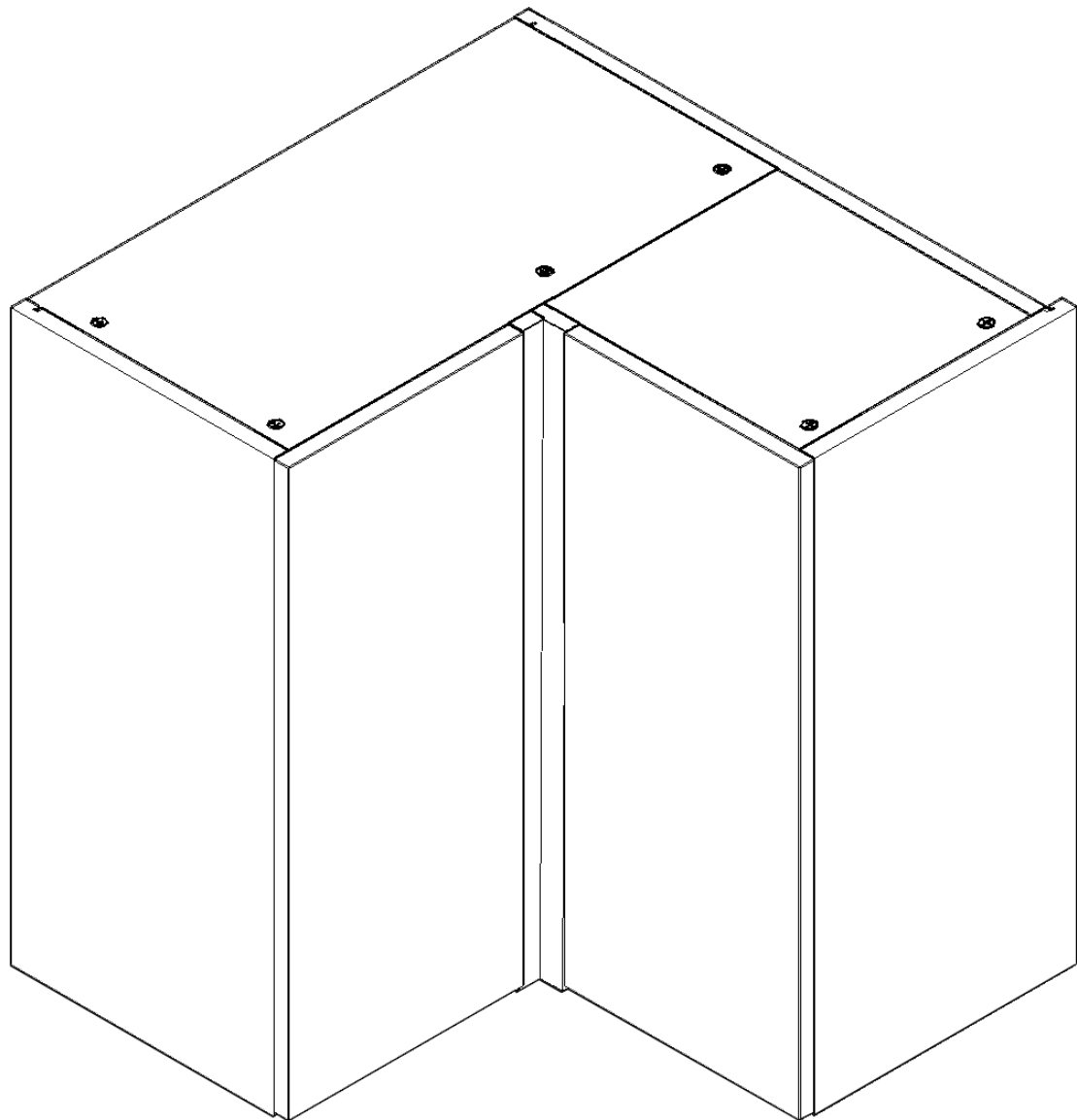

# WALL UNIT

## 672 L Corner Assembly Guide

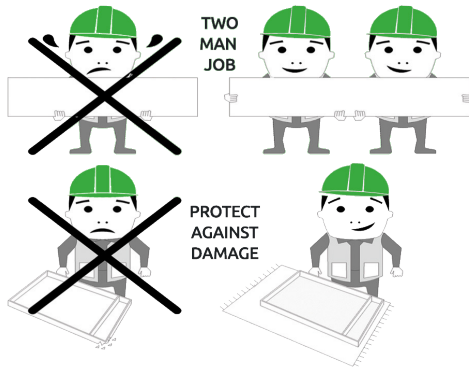

**BEFORE YOU START**

**INSTALLATION SHOULD BE PERFORMED BY A COMPETENT PERSON ONLY.**

**THIS PRODUCT COULD BE DANGEROUS IF INCORRECTLY INSTALLED**

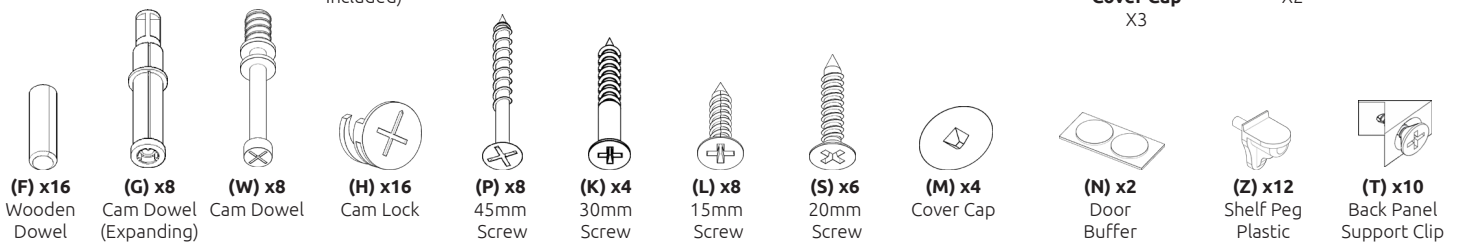
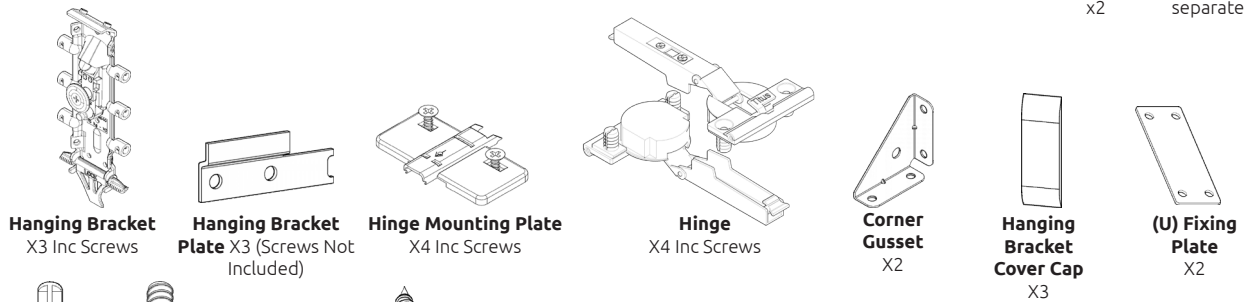
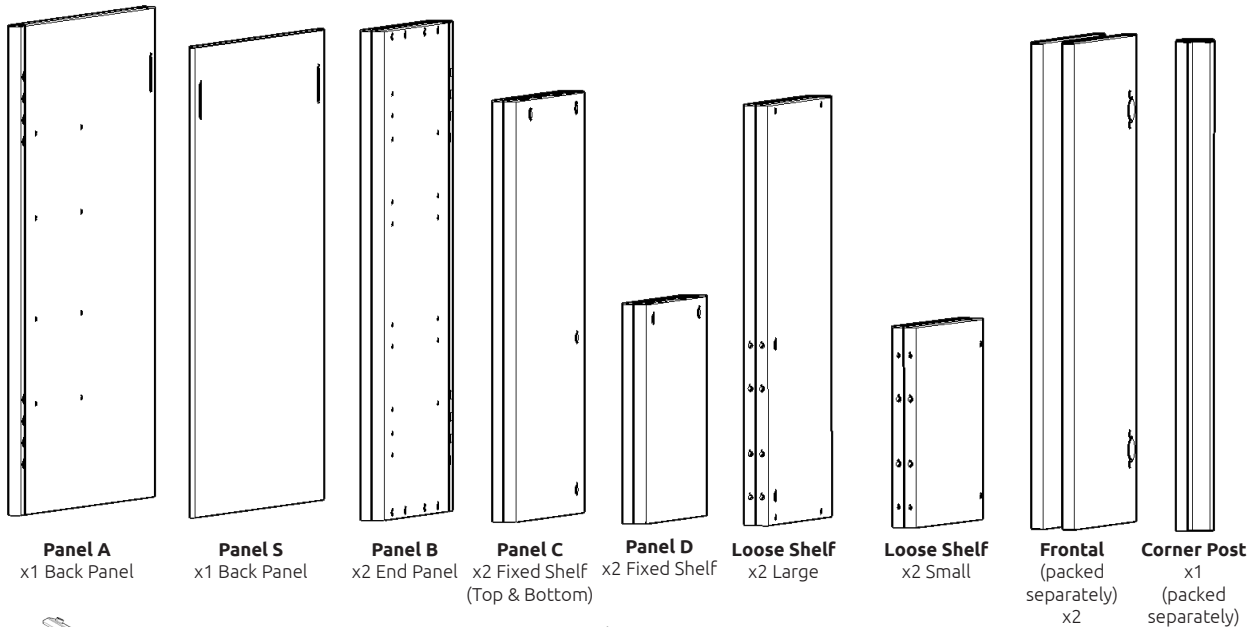

**REQUIRED TOOLS**



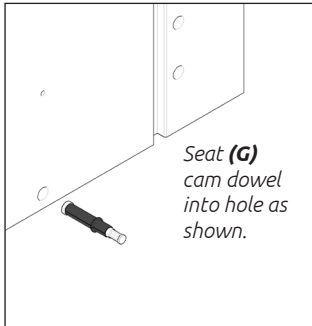

**Step 1.**  
Seat dowel (F) into holes in both end panels (B) as shown.

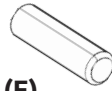

**Step 2.**  
Seat cam dowel (G) into holes in both end panels (B) as shown.

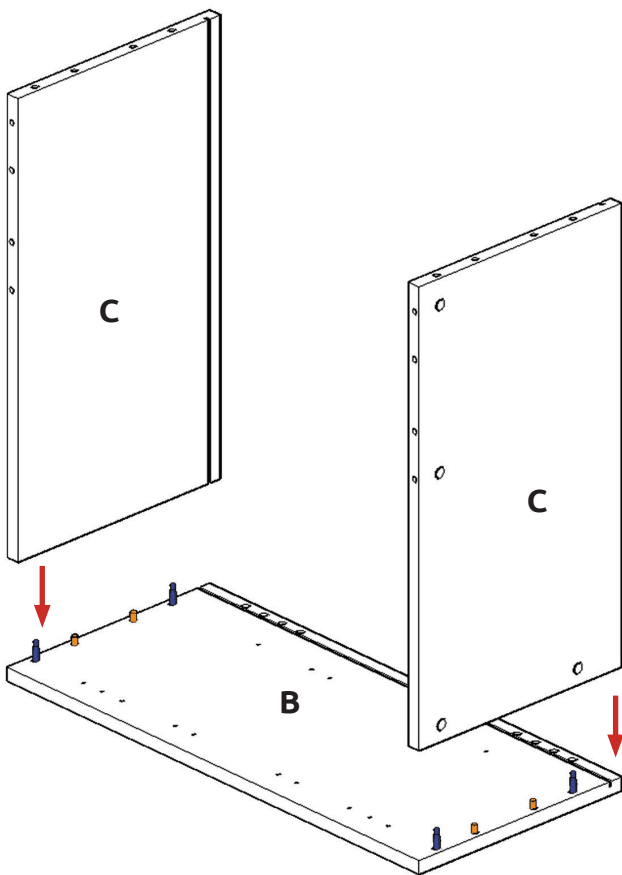
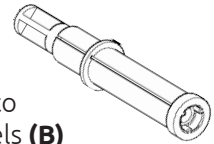

**Step 3.**  
Attach panels x2 (C) to panel (B), using cam dowels (G) (in blue), and also using dowels (F) (in orange) in positions as shown.

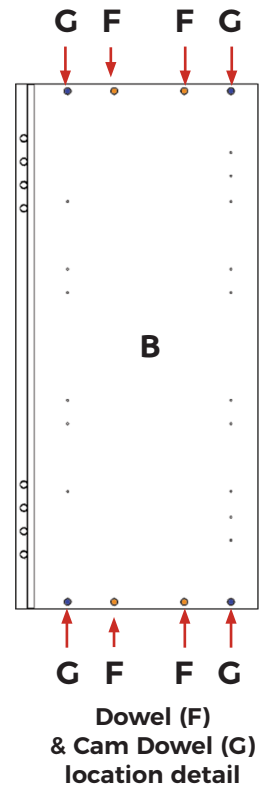

**!** All cam locks (H) are to be positioned facing the outside of the unit carcass, for ease of tightening.

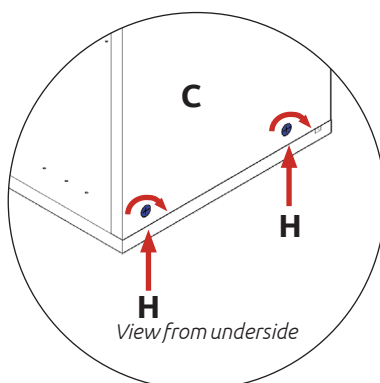
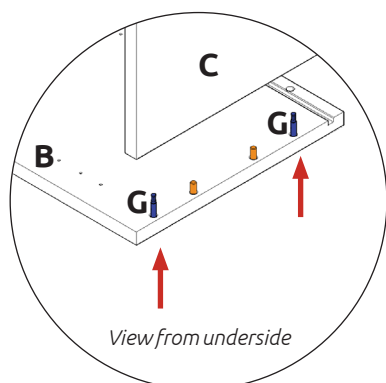

Do **not** use power tools with cam dowel (G) or cam lock (H)

**Step 4.**  
Insert cam lock (H). Hand tighten all cam locks (H), this will expand the cam dowels (G) and tighten the unit together.



# WALL UNIT

## 672 L Corner Assembly Guide

### Step 5.

Seat dowel (F) into holes in both panels (B) as shown.

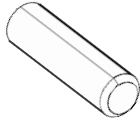

### Step 6.

Seat expanding cam dowel (G) into holes in both end panels (B) as shown.

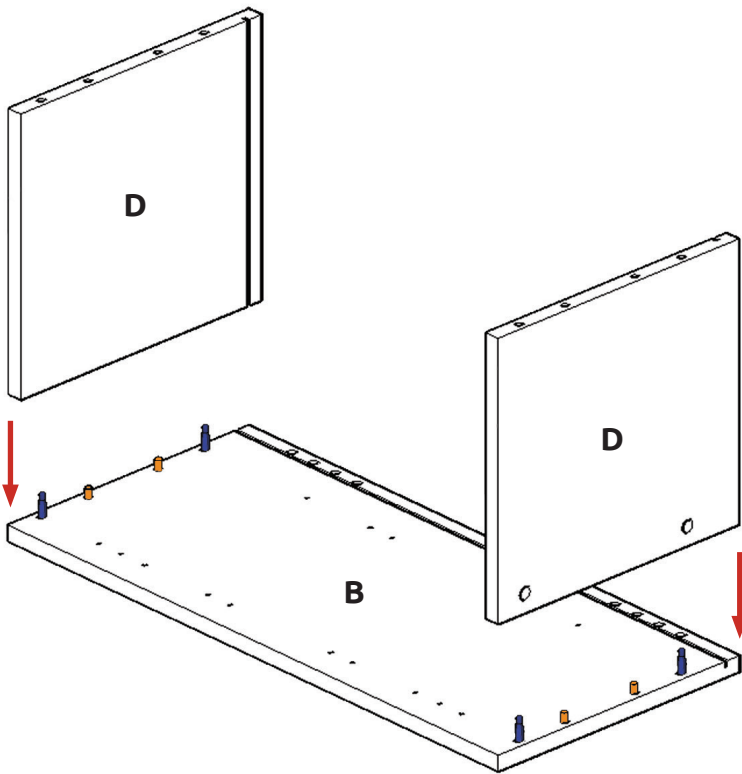
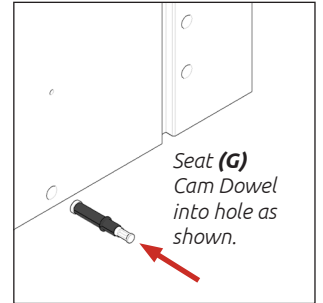
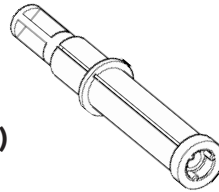

### Step 7.

Attach panel (B) to panels (D) using cam dowels (G) (in blue) and also using dowels (F) (in orange) in positions as shown.

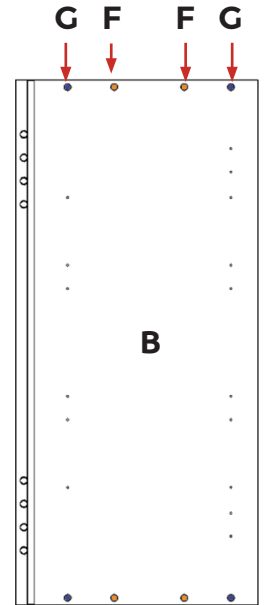

Dowel (F) & Cam Dowel (G) location detail



All cam locks (H) are to be positioned facing the outside of the unit carcass, for ease of tightening.

Do **not** use power tools with cam dowel (G) or cam lock (H)

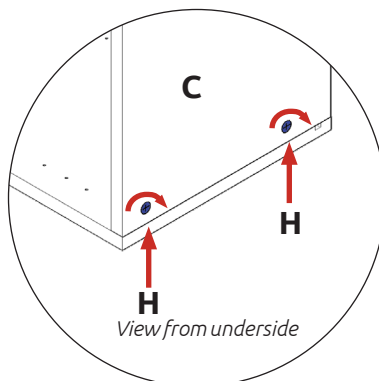
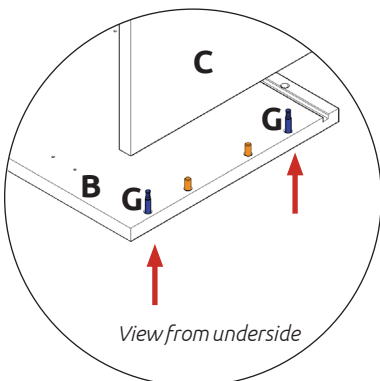

### Step 8.

Insert cam lock (H). Hand tighten all cam locks (H), this will expand the cam dowels (G) and tighten the unit together.

**Step 9.**  
Seat dowel (F) into holes in both panels (D) as shown.

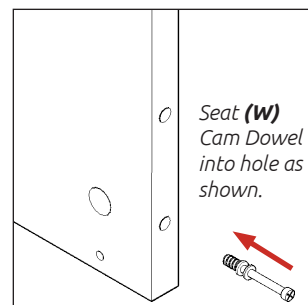
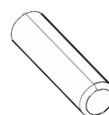

**Step 10.**  
Seat cam dowel (w) into holes in panel (D) as shown.

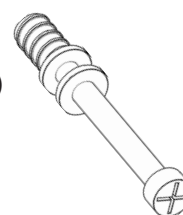

**Step 11.**  
Attach panels x 2 (D) to panels (C) using cam dowels (W) (in blue) and also using dowels (F) (in orange) in positions as shown.

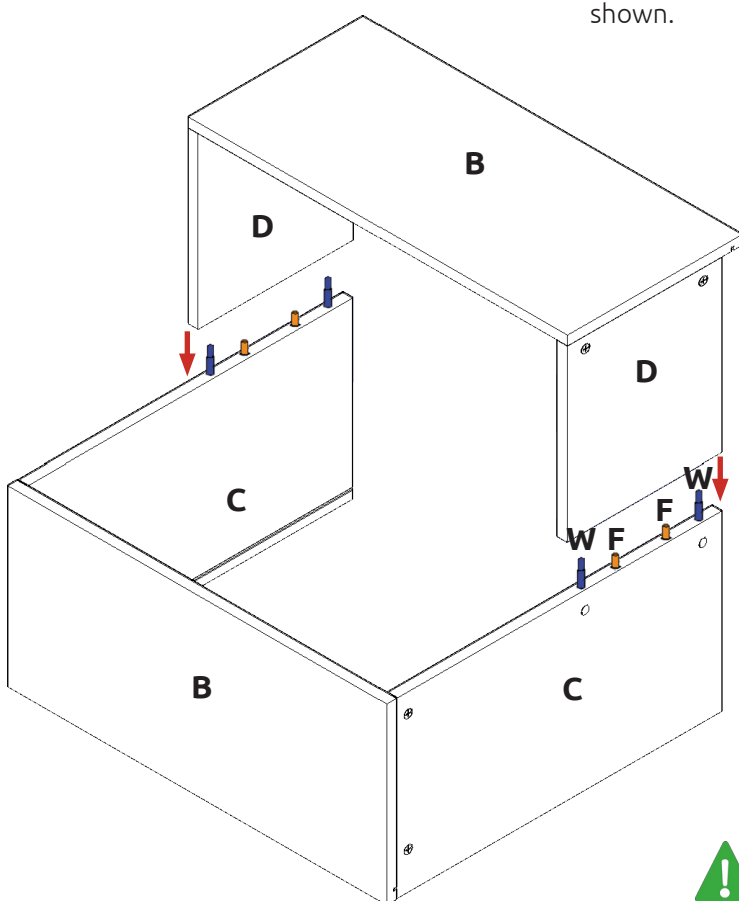

Do **not** use power tools with cam dowel (G) or cam lock (H)



All cam locks (H) are to be positioned facing the outside of the unit carcase, for ease of tightening.

**Step 12.**  
Insert and hand tighten all cam locks (H).

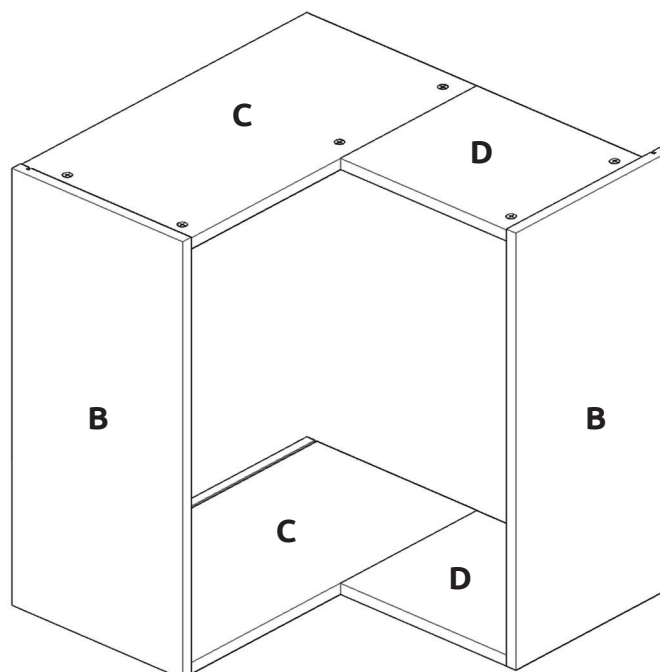
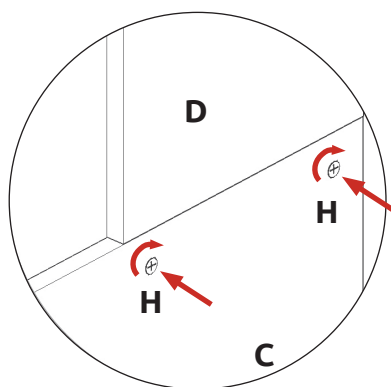

# WALL UNIT

## 672 L Corner Assembly Guide

### Step 13.

Slide back panel (S) into groove of panels (C).

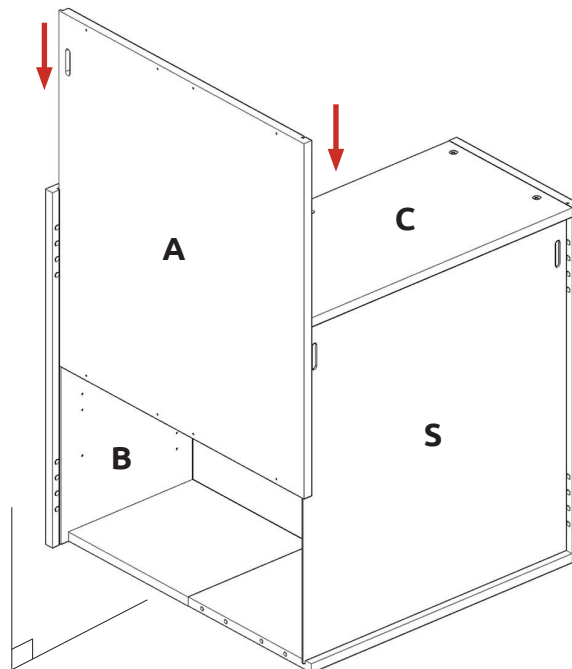
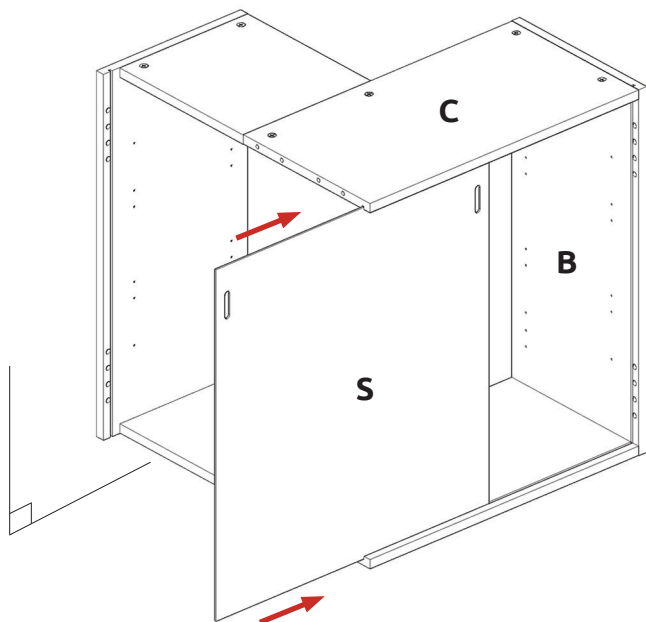

### Step 14.

Slide back panel (A) into groove of side panel (B) while also allowing panel (S) slide into the groove of panel (A).

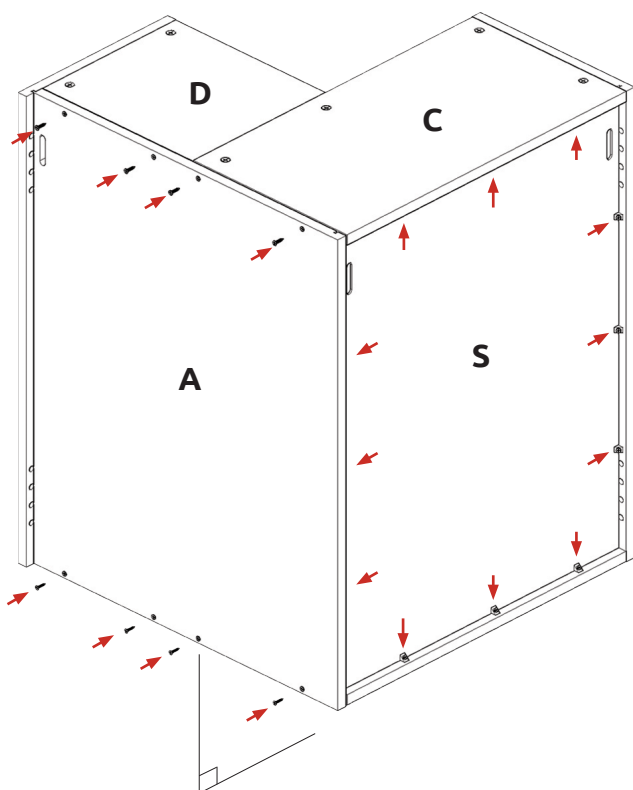

### Step 15.

Ensure all panels are square. Screw back panel (A) to panels (C) & (D) with 8 x screws (P) using provided pilot holes.

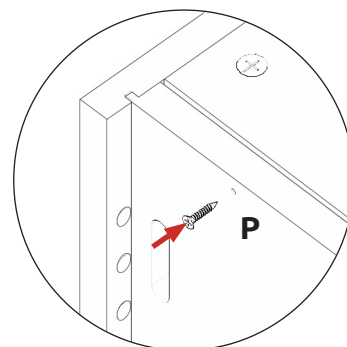

### Step 16.

Slide 9 x back panel clips (T) into the groove of both panels (A), (B) & (C). The back panel clips (T) should be evenly spaced as shown and positioned to allow the hanging bracket and corner gussets to be fitted. Once in place, tighten screw.

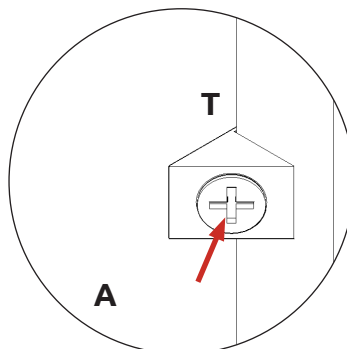
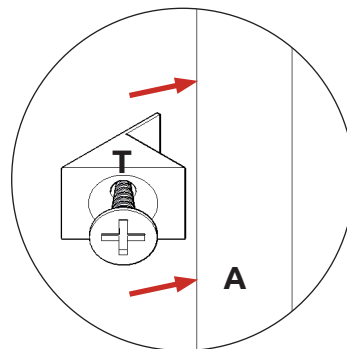



Screws for attaching to walls are not provided as these vary depending on materials, thickness and construction. Ensure appropriate fixings for wall construction are used.



Care to be taken. Hanging procedure is necessary for a safe installation.

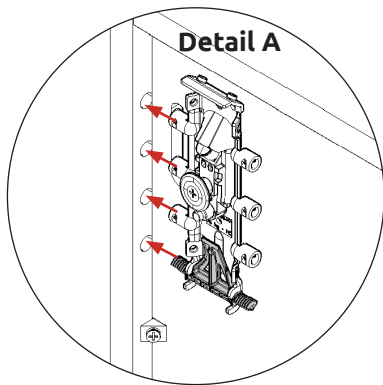

**Step a**

Insert hanging bracket into pre-drilled holes

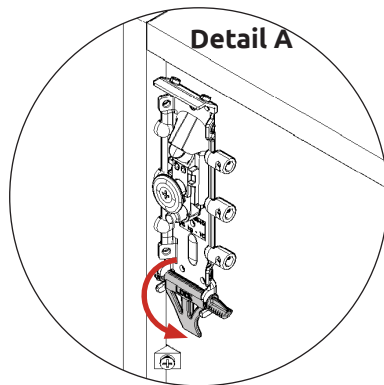

**Step b**

Rotate locking lever 180 degrees

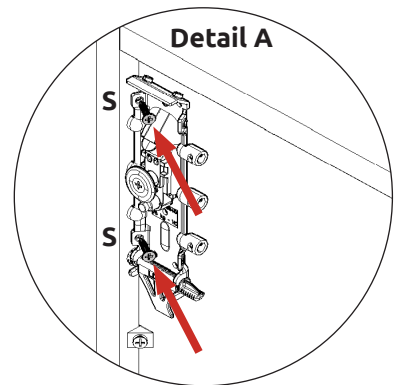

**Step c**

Secure with provided 2 x 20mm screws (**S**) per bracket

**Step 17.** Hanging Brackets steps a, b & c to be carried out on both sides as shown

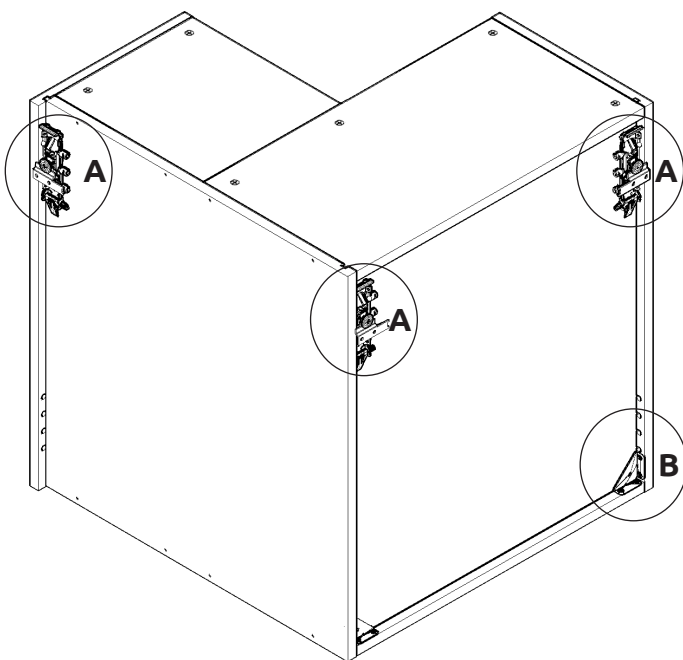

**Step 18.**

Secure corner gussets to the bottom left and right hand side of the wall unit using 4 x 15mm screws (**L**) per plate.

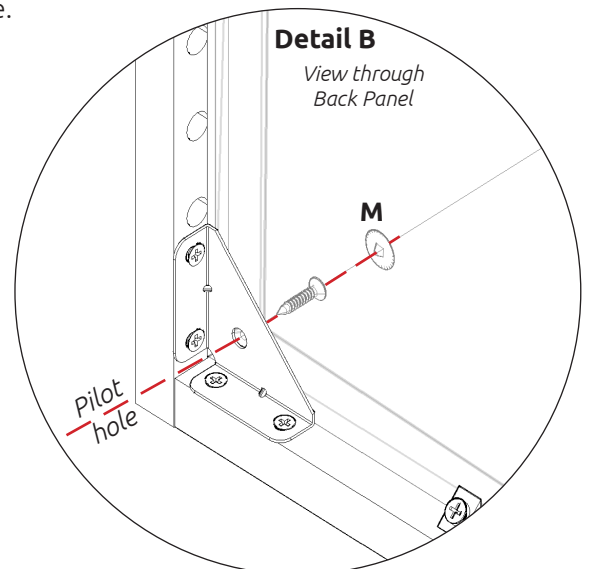
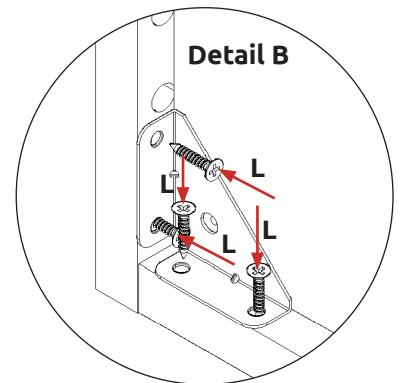

**Step 19.**

Drill a small pilot hole through the centre of the corner gussets, through the back panel. Use this hole at the end of the process to screw through and into the wall. Cover the screw heads using the cover caps (**M**) provided.



Screws for attaching to walls are not provided as these vary depending on materials, thickness and construction. Ensure appropriate fixings for wall construction are used.

### Step 20.

Measure appropriately and attach the 3 x hanging bracket plates onto the wall screwing through the provided holes into your wall.

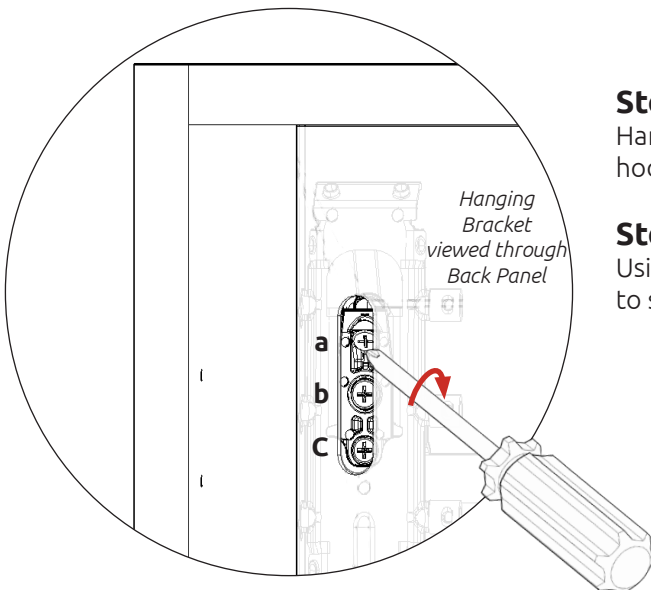
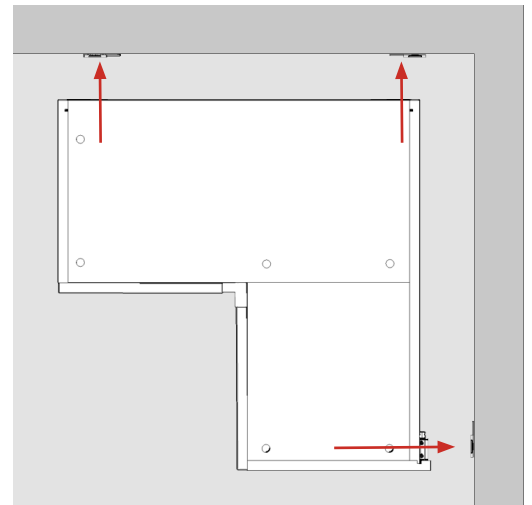
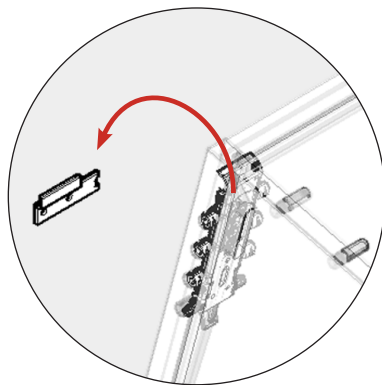
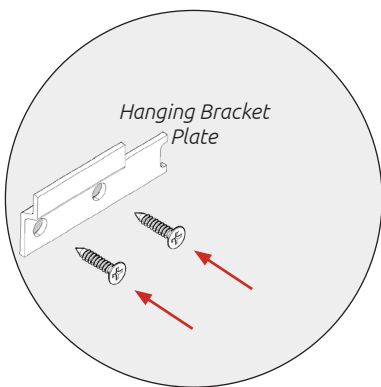

### Step 21.

Hang the unit using the brackets to hook onto the plate as shown

### Step 22.

Using points a, b & c adjust the unit to suit.

#### Step a.

Rotate the screw clockwise to move the unit up. Anti-clockwise for down.

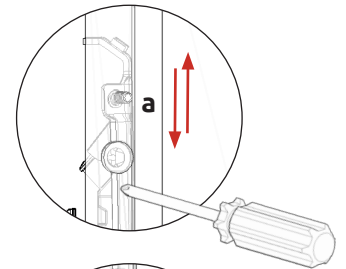

#### Step b.

Adjust the depth using centre screw.

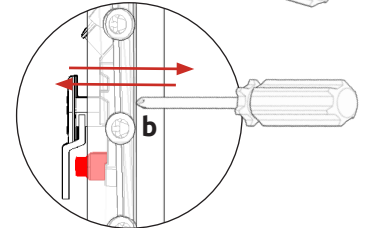

#### Step c.

Screw the red screw until it touches the plate to lock in position.

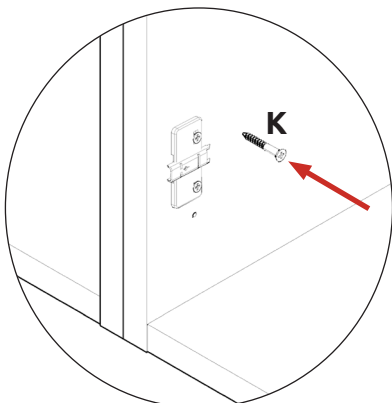
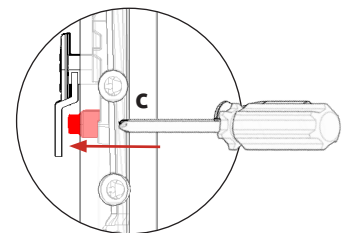

### Step 23.

Screw into any side units using the provided 2 x 30mm screws (K) to secure the unit. Screw just to the rear of the hinge plate then place a cover caps (M) on the head to conceal it.



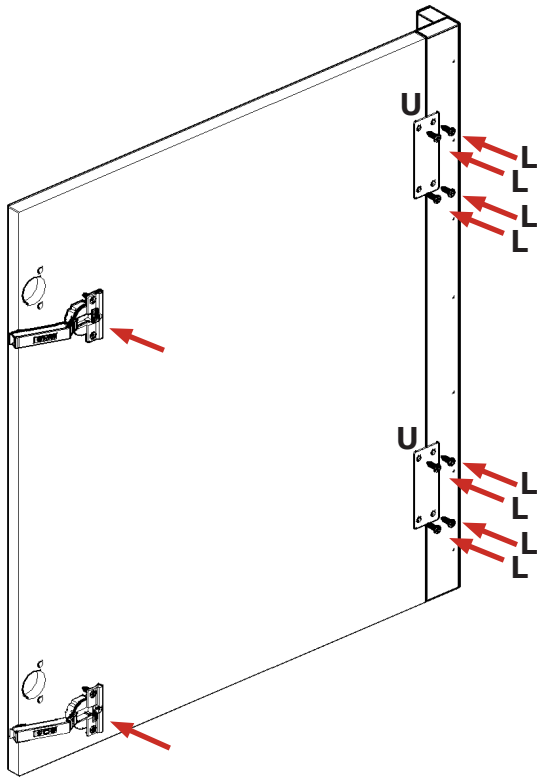

### Step 24.

Align corner post to frontal. Equally space 2 x fixing plates (U) to the back of frontal & corner post. Ensure a 4 mm gap is maintained between frontal & post once fixed together. Screw in place using 4 x 15mm screws (L) per fixing plate (U).

### Step 25.

Insert hinge in top & bottom holes as shown below.

### Step 26.

Secure hinges by tightening 2 x screws with hinge dowels attached. These are already positioned within the hinges.

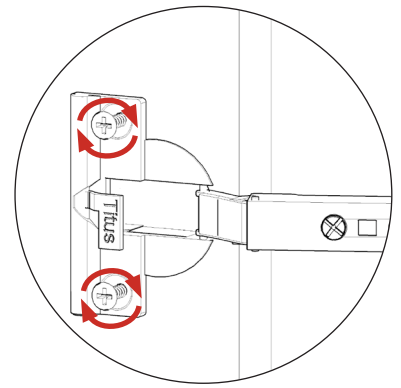

### Step 27.

Attach the door to unit where required. To attach door, clip hinge onto hinge plate and click to secure.

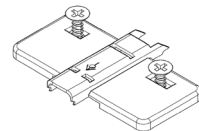

Hinge Plates

### Step 28.

Adjust hinge to suit. As shown below.

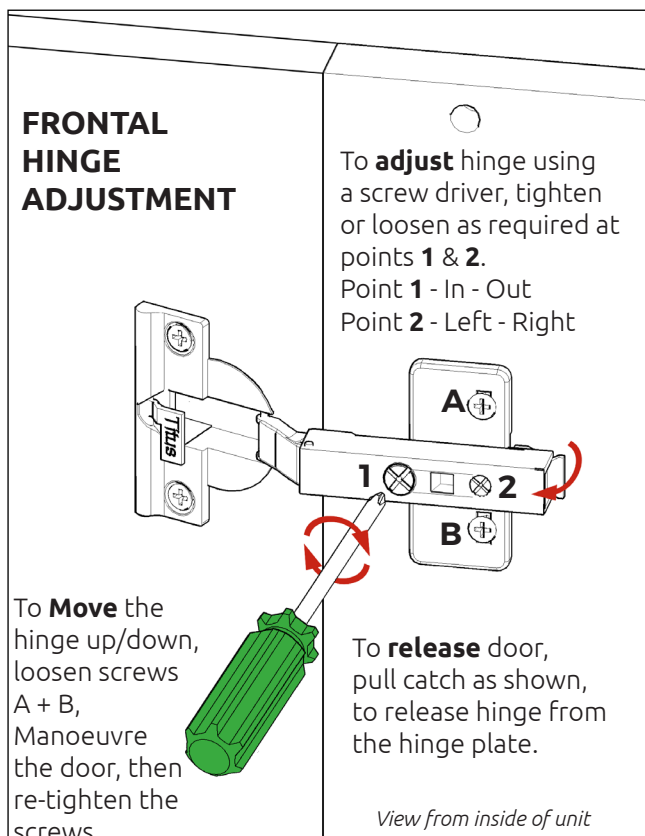

### Step 29.

Fit cover caps to hinge. Adjust Soft close to suit.

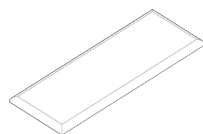

Hinge Cover Caps

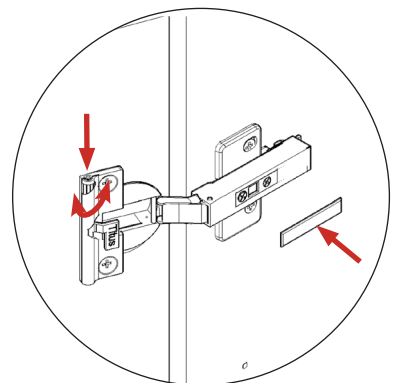

The top and bottom hinges **MUST** be adjusted to the **SAME STRENGTH**.

*Vogue*

# WALL UNIT

672 L Corner Assembly Guide



**wren**  
KITCHENS