

Vogue

BASE UNIT

Hob 2 Drw, 3 Drw & 2 Drw inc Dummy Assembly Guide

600
2 Drawers

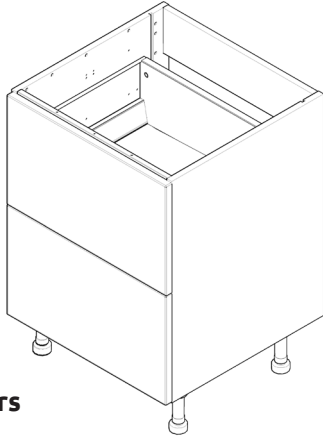

600 2 Drawer inc
Dummy Drawer

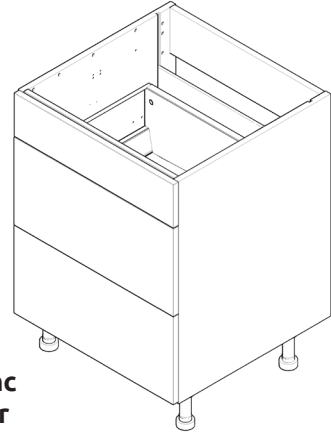

800
2 Drawers

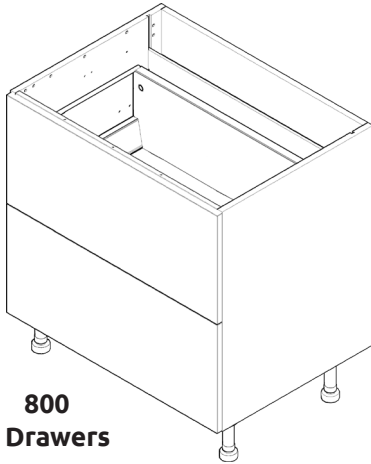

800 2 Drawer inc
Dummy Drawer

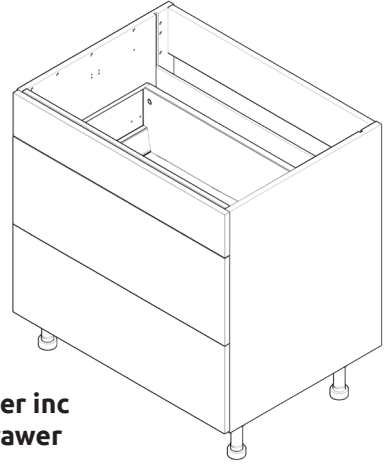

1000
3 Drawers

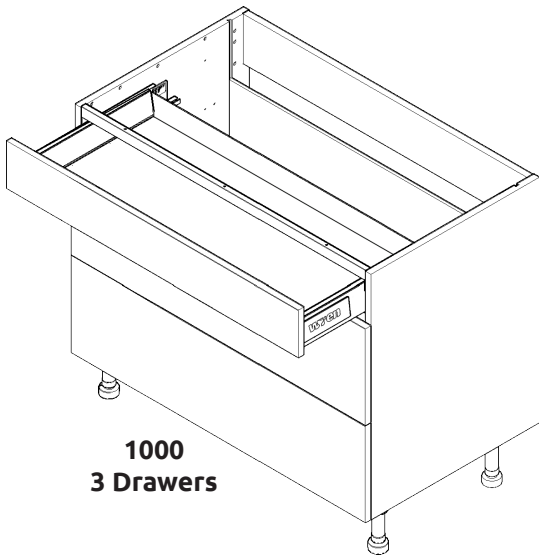

1000 2 Drawer inc
Dummy Drawer

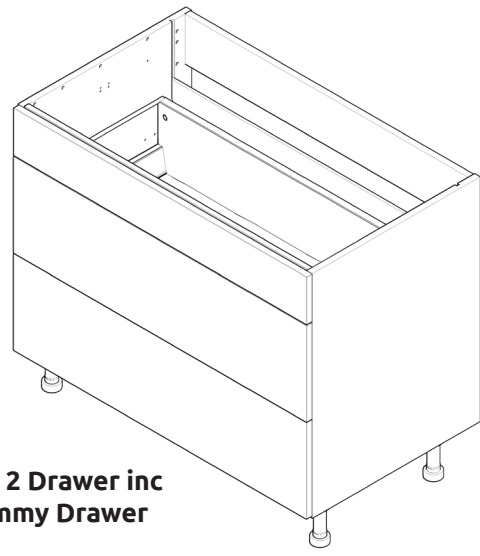

BASE UNIT

Hob 2 Drw, 3 Drw & 2 Drw inc Dummy Assembly Guide

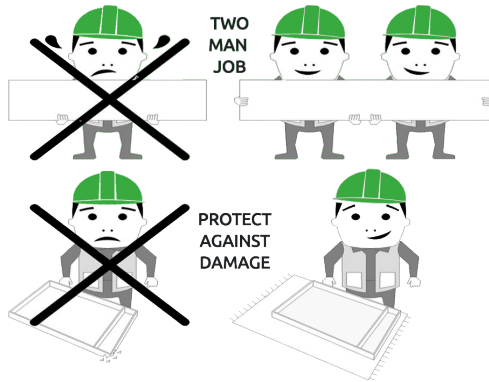

BEFORE YOU START

INSTALLATION SHOULD BE PERFORMED BY A COMPETENT PERSON ONLY.

THIS PRODUCT COULD BE DANGEROUS IF INCORRECTLY INSTALLED

Standard Drawer (Packed Separately)

Fitting Pack Contents

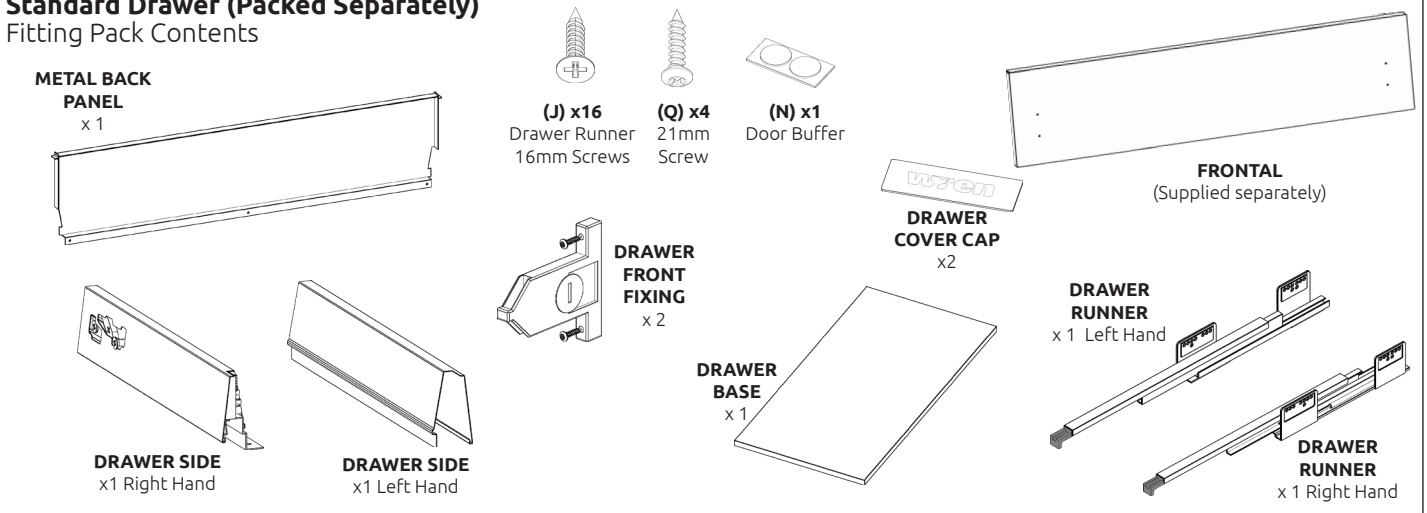

Deep Drawer (Packed Separately)

Fitting Pack Contents

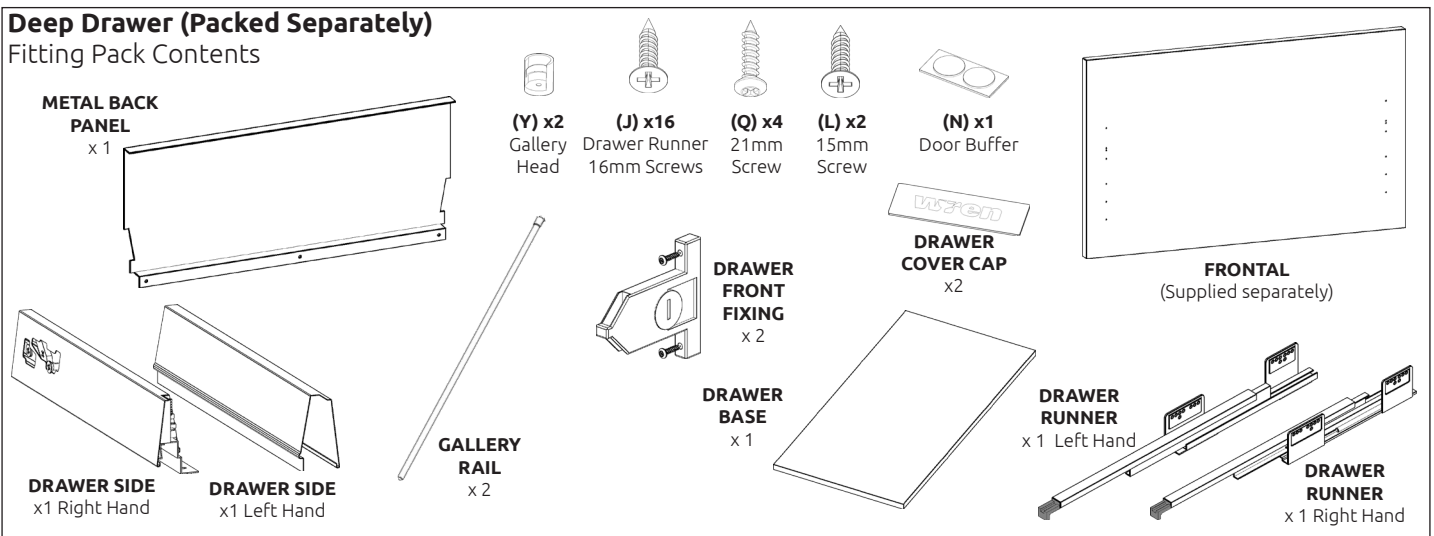

REQUIRED TOOLS



Step 1.

Secure drawer base to drawer side using 4 x 16mm drawer runner screws (**J**) in holes provided.

Seat the edge of drawer base tight into corner of casing, as shown.

The decorative face of drawer base to be positioned as shown.

Repeat step 1 so both drawer sides are attached to drawer base.

Step 2.

Clip on metal back panel to drawer base & drawer sides.

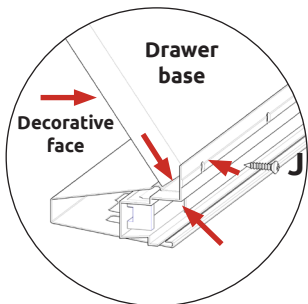

Front of drawer

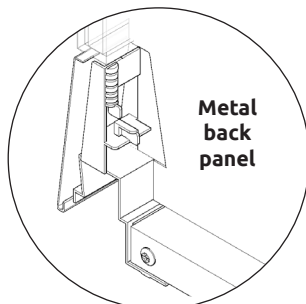

View from back

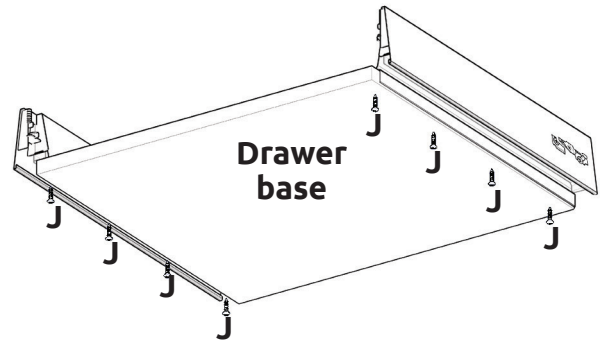

Step 3.

Screw back panel in position using 2 x 16mm screws (**J**) to drawer base in holes provided.

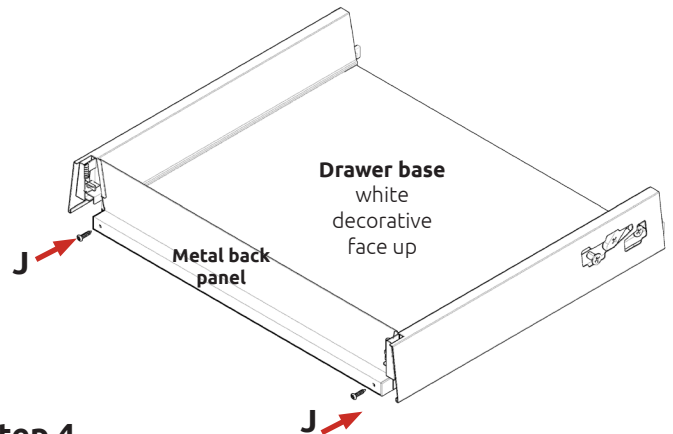

Step 5.

Draw Adjustment
Screw point **1** as shown to adjust drawer frontal right & left.

Screw point **2a** as shown to adjust drawer frontal up & down.

Tighten **2b** once in position.

Releasing **fixing clip**. Screw point **3** whilst applying downward pressure as shown to release.

View of drawer side

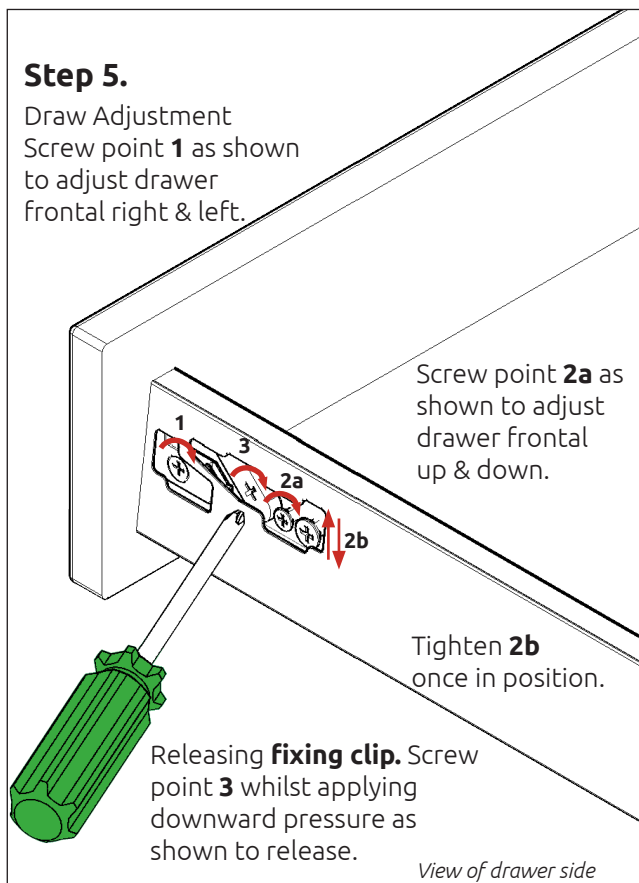

Step 4.

Frontal Attachment
Secure drawer side fixing clips using 2 x 21mm screws (**Q**) in pilot holes provided as shown.

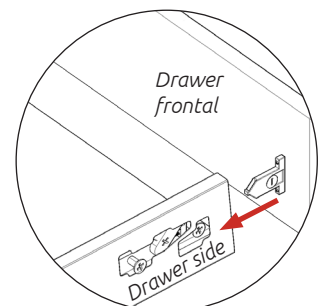
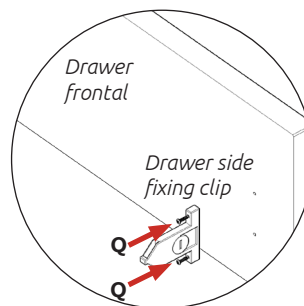
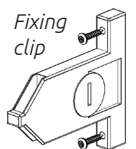

Step 6.

Fit drawer cover caps over drawer side adjustment.

BASE UNIT

Hob 2 Drw, 3 Drw & 2 Drw inc Dummy Assembly Guide

Step 1.

Secure drawer base to drawer side using 4 x 16mm drawer runner screws (**J**) in holes provided. Seat the edge of drawer base tight into corner of casing, as shown. The decorative face of drawer base to be positioned as shown.

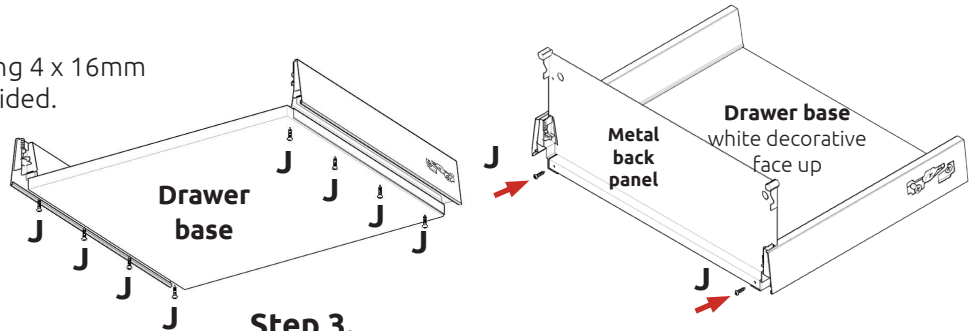

Repeat step 1 so both drawer sides are attached to drawer base.

Step 2.

Clip on metal back panel to drawer base & drawer sides.

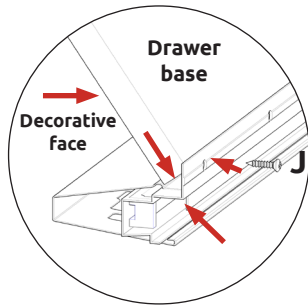

Front of drawer

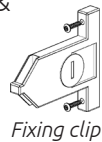

Fixing clip

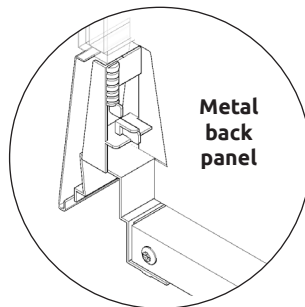

View from back

Step 3.

Screw back panel in position using 2 x 16mm screws (**J**) to drawer base in holes provided.

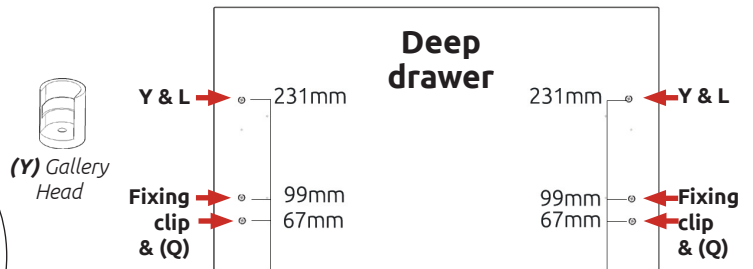

Step 4.

Secure drawer side fixing clips using 2 x 21mm screws (**Q**) & gallery head (**Y**) using 1 x 15mm screws (**L**) in pilot holes provided as shown.

Drawer Frontal Adjustment

Step 5.

Draw Adjustment
Screw point **1** as shown to adjust drawer frontal right & left.

Screw point **2a** as shown to adjust drawer frontal up & down.

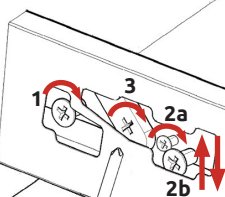

Releasing fixing clip.
Screw point **3** whilst applying downward pressure as shown to release.

Tighten **2b** once in position.

View of drawer side

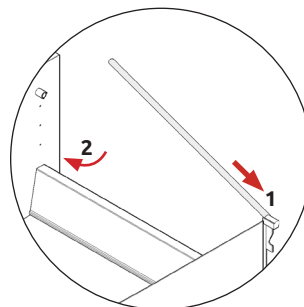
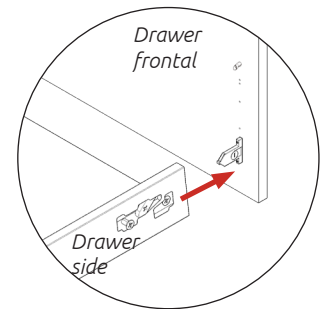
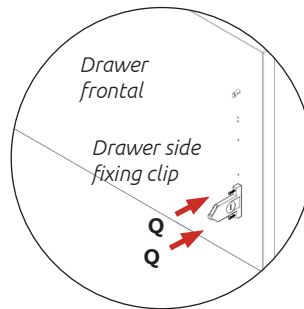

Step 6.

Fit gallery rail into the top corners of metal back panel. Locate front end of the gallery rail into the opening of the gallery head, which is secured to the frontal as shown

Step 7.

Fit drawer cover caps over drawer side adjustment.



Drawer Cover Cap

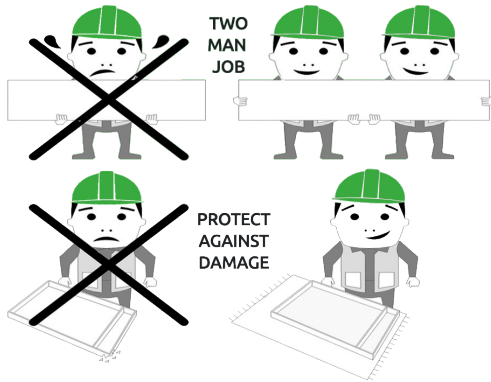

BEFORE YOU START

INSTALLATION SHOULD BE PERFORMED BY A COMPETENT PERSON ONLY.

THIS PRODUCT COULD BE DANGEROUS IF INCORRECTLY INSTALLED

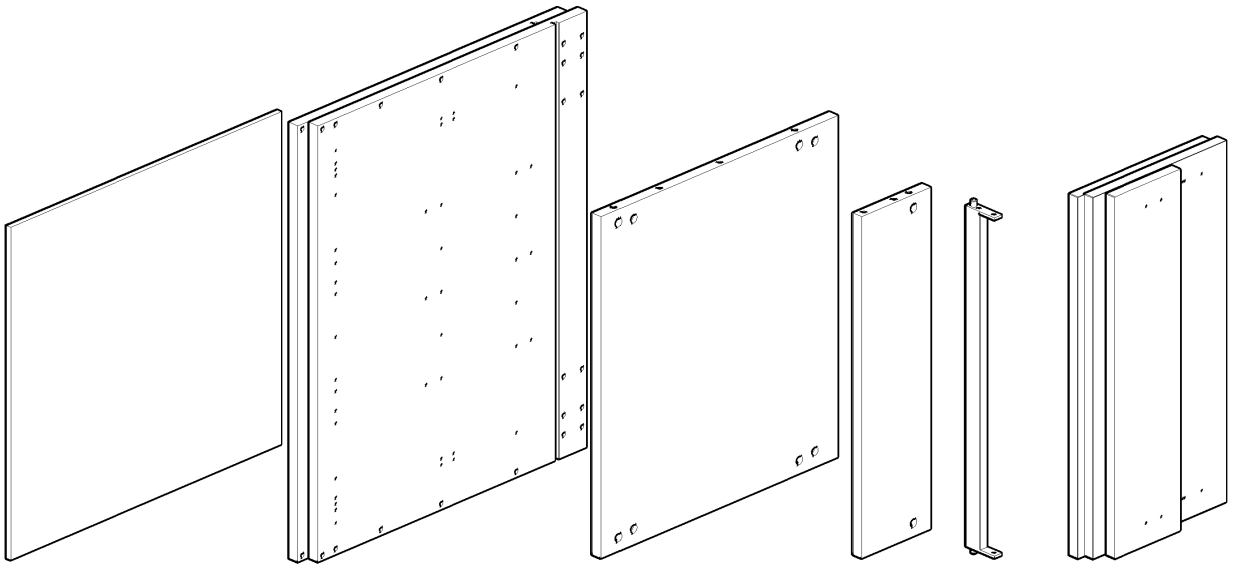

Panel A
x1 Back Panel

Panel B
x2 End Panel

Panel C
x1 Base Panel

Panel E
x1 Rail

Metal Rail
x1

Frontal
(Packed separately)
Qty as per order

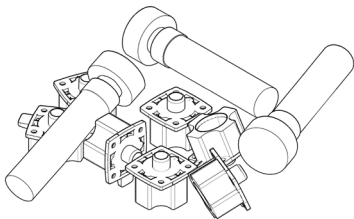

Legs
Qty as per order



(F) x8
Wooden Dowel

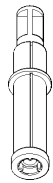

(G) x6
Cam Dowel (Expanding)



(H) x6
Cam Lock



(K) x4
30mm Screw



(L) x12
15mm Screw



(M) x4
Cover Cap

REQUIRED TOOLS



NOT to be used with CAM DOWEL & CAM LOCK

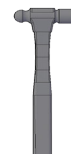

BASE UNIT

Hob 2 Drw, 3 Drw & 2 Drw inc Dummy Assembly Guide

Step 1.

To attach drawer runner screw into end panels (**B**) using 2 x 16mm screws (**J**) per drawer rail, into pilot holes provided, as shown.

Drawer runner bracket screw position

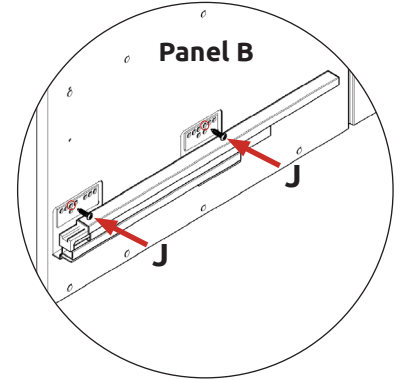
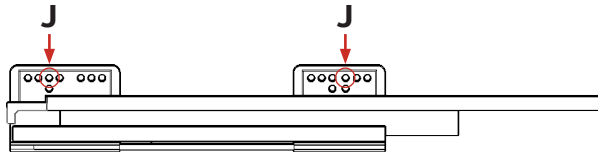

Step 2.

Where applicable, secure dummy fixing clip parts (**A**) onto both End Panels (**B**) using 2 x 15mm screws (**L**) each, as shown. The top screw hole is to be positioned 52mm from the top of the panel (marked by an indentation).

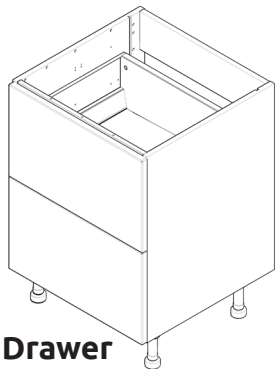
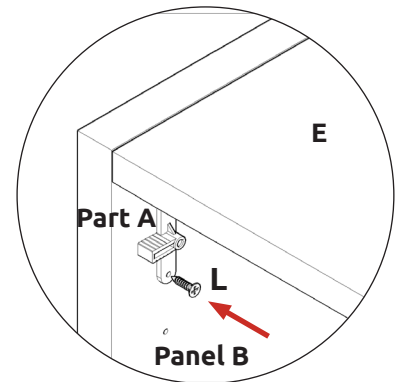
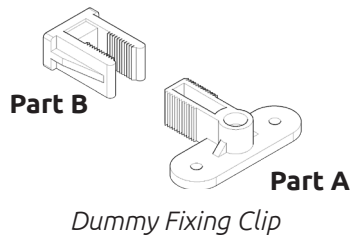

2 Drawer

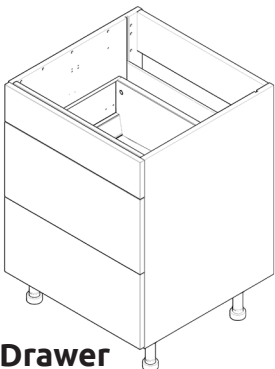

2 Drawer inc Dummy Drawer

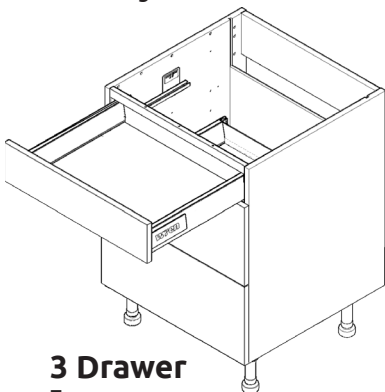

3 Drawer

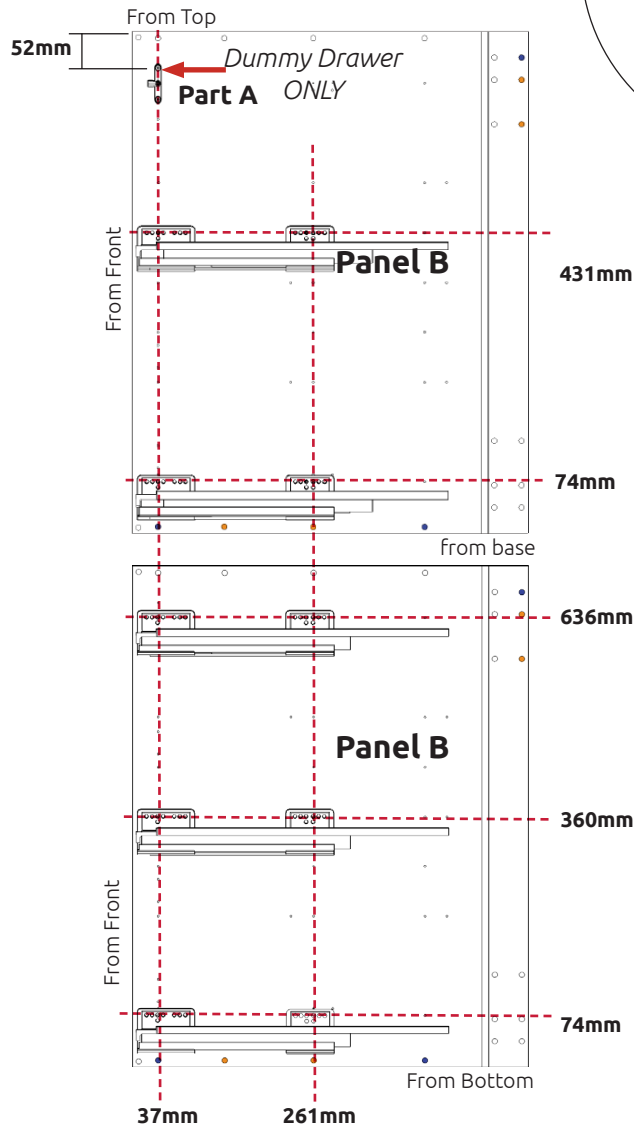

- 2 Drawer
- 2 Drawer inc Dummy Drawer

3 Drawer

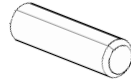
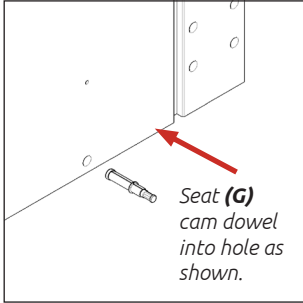

Step 3.

Seat dowel (F) into holes in both end panels (B) as shown.

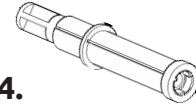

Step 4.

Seat cam dowel (G) into holes in both end panels (B) as shown.

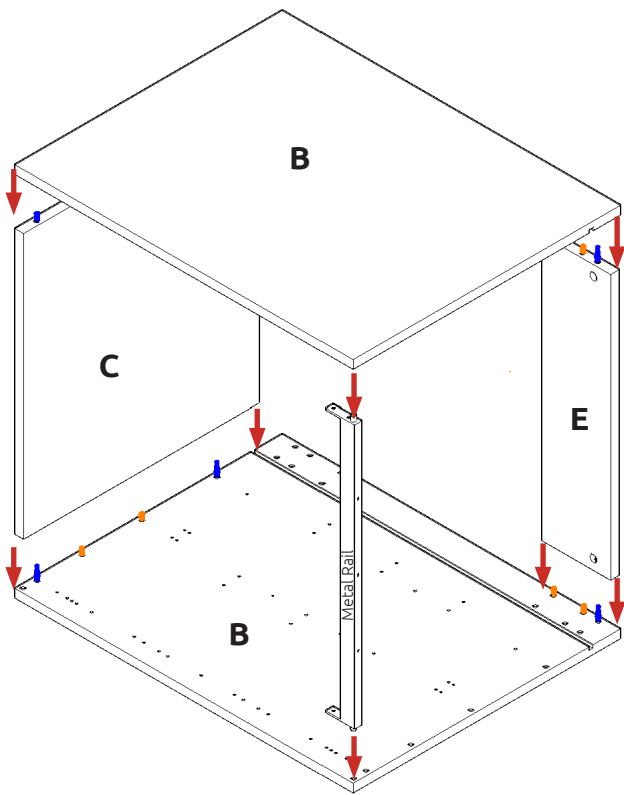

Metal Rail Insert

Metal Rail Insert

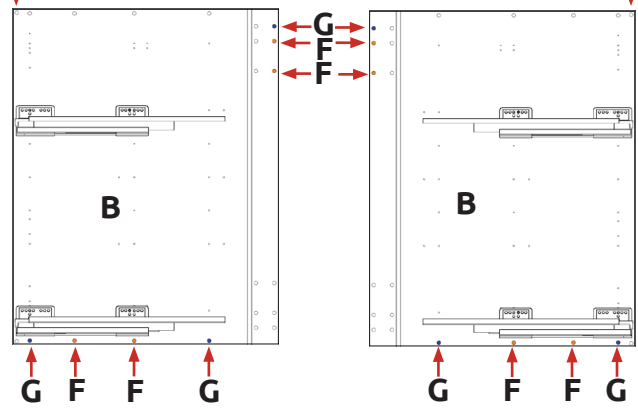

Dowel (F), Cam Dowel (G) & Metal Rail Screw Location detail

Step 5.

Attach panels (C) & (E) to panels (B), using dowels (F) (orange) and cam dowel (G) (blue) in positions shown. Insert metal rail as shown & secure with 2 x 15mm screws (L) into panels (B).



All cam locks (H) are to be positioned facing the outside of the unit carcass, for ease of tightening.

Do **NOT** use power tools with cam dowel (G) or cam lock (H)

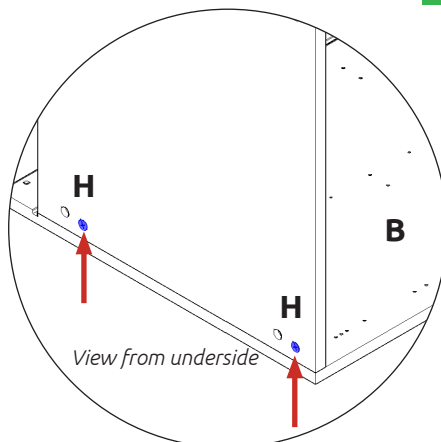
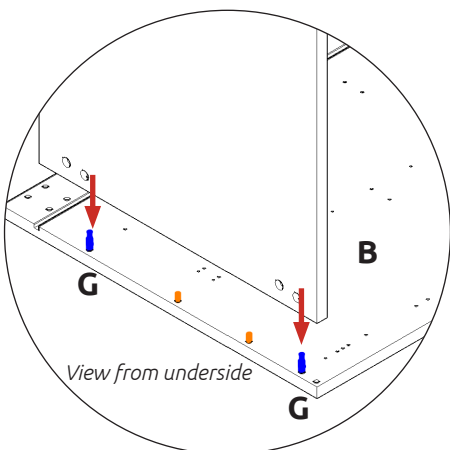

Step 6.

Insert cam lock (H). Do **NOT** tighten until Step 8.



BASE UNIT

Hob 2 Drw, 3 Drw & 2 Drw inc Dummy Assembly Guide

Step 7.

Slide back panel (A) into groove of end panels (B).

The back panel (A) is to be modified accordingly to suit Customer Requirements, prior to inserting into unit.

Once back panel (A) is in position, ensure the panel is flush & square with bottom of end panels (B).

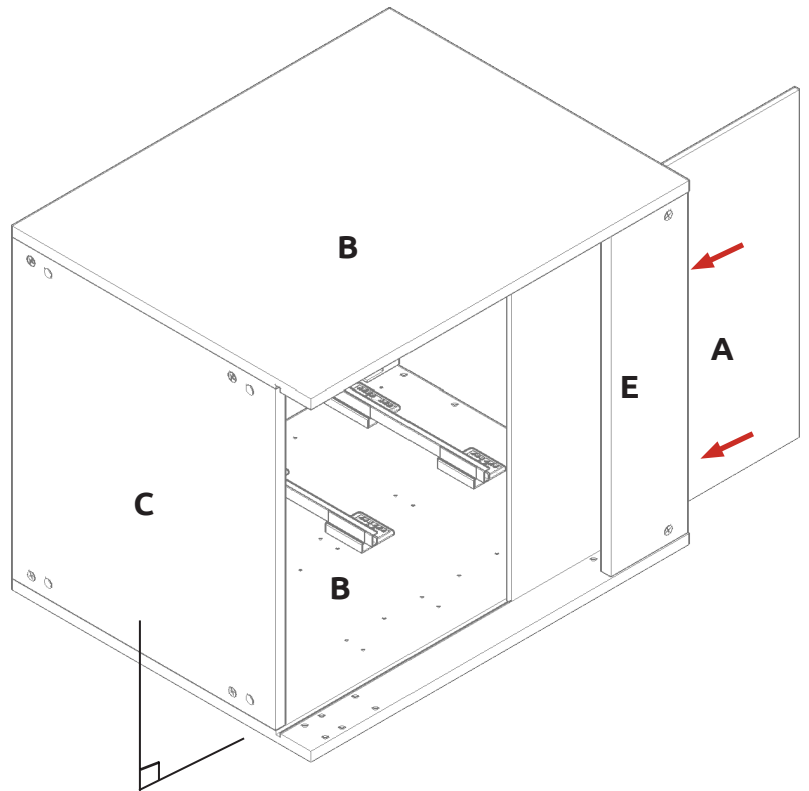

600 unit used for reference only

Step 8.

Hand tighten all cam locks (H), this will expand cam dowels (G) and tighten the unit together.

Step 9.

Ensure unit is square. Secure back panel (A) with 3 or 4 x 30mm screws (K) equally spaced at the bottom of back panel (A) into base panel (C), as shown.

Ensure you screw into the centre of the base panels (C) (9mm from the edge).

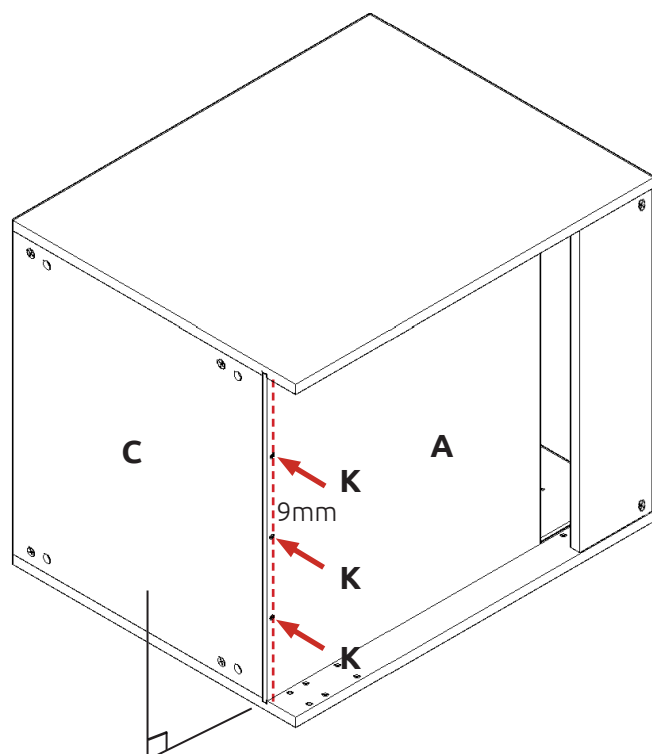

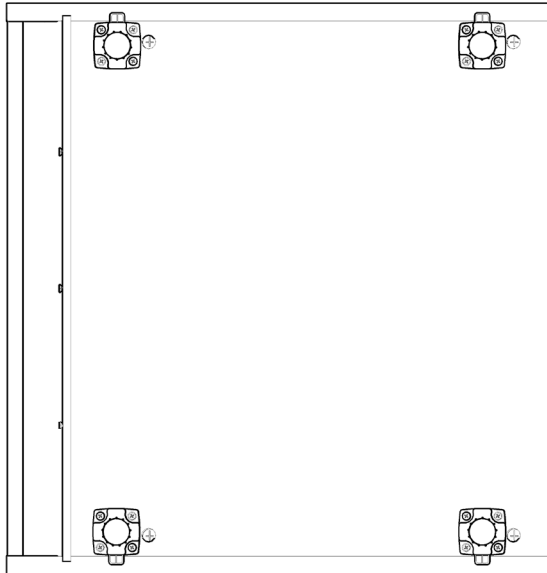

Step 10.

Position legs as shown.
 Ensure legs are rotated to also provide support to the end panels (**B**).
 600-800 width unit, 4 legs
 1000 width units, 5 legs.

Step 11.

Secure each of the legs into place with 4 x 15mm screws (**L**) per leg.

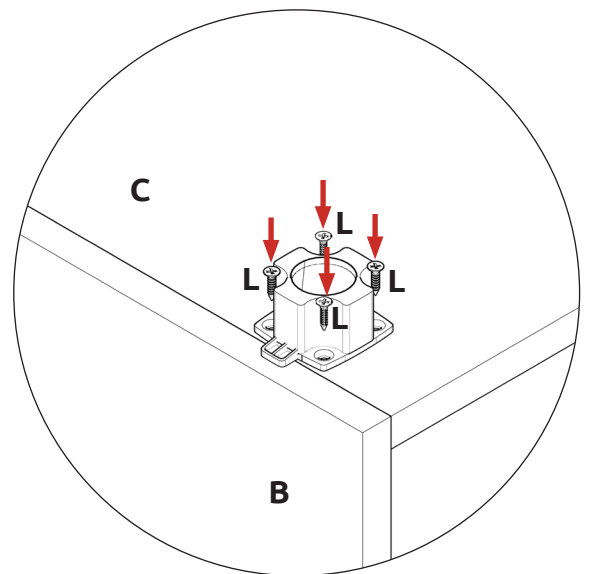

Step 12.

Push leg firmly down into leg base.
 Adjust legs to 155mm before turning unit upright. Once in situ level accordingly.

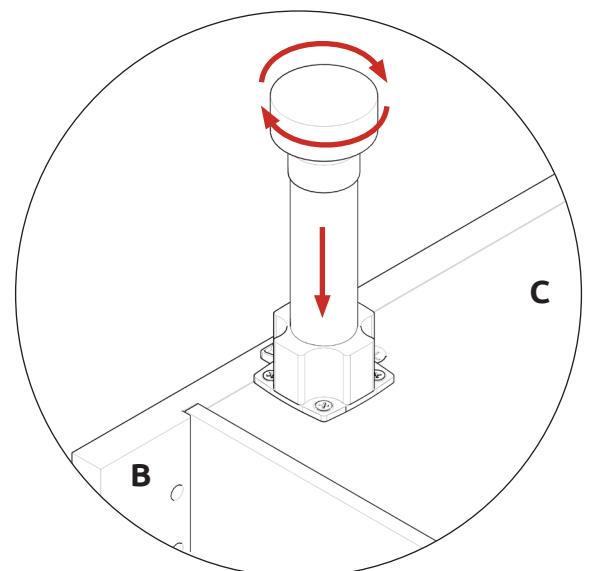

It is **important** to lift the unit onto its legs. Do not tilt as depicted in the image.

BASE UNIT

Hob 2 Drw, 3 Drw & 2 Drw inc Dummy Assembly Guide

Screw into any side units using the 30mm screws (**K**) provided to secure to the unit. Screw just to the rear of the indentations at the top and bottom on both sides of the unit where applicable. Place cover caps (**M**) on the heads of the screws to conceal them.

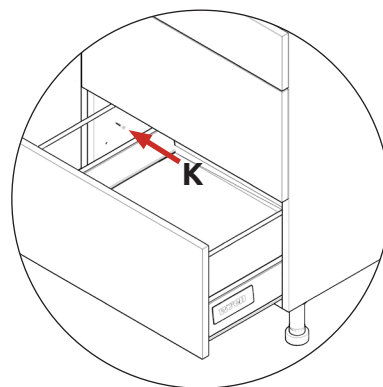

Screws for attaching to walls and worktop are not provided as these vary depending on materials, thickness and construction. Ensure appropriate fixings for wall and worktop construction are used. Please refer to the specialist worktop supplier if these are required for solid surface worktops.

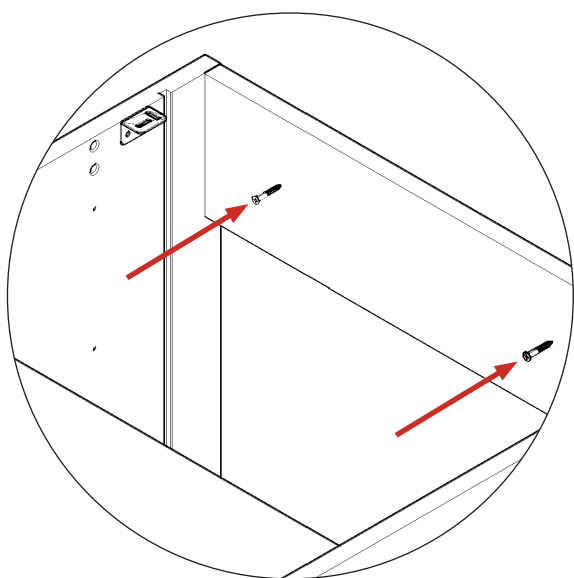

Screw up through the metal rail into worktop to secure it in place.

Secure unit to wall by screwing through the back rail and into the wall.

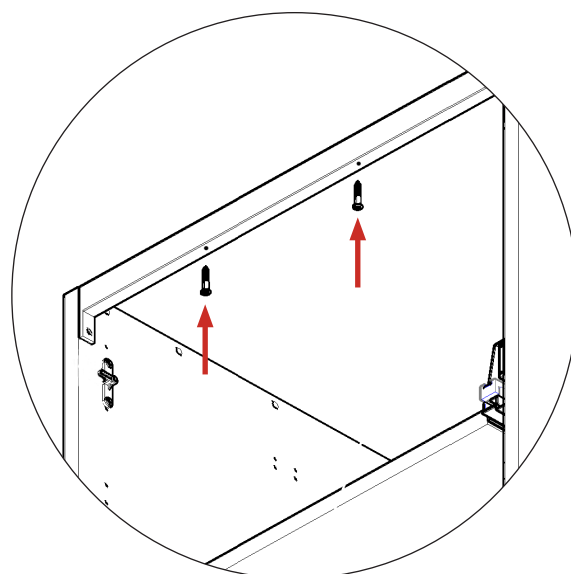

Dummy Drawer Frontal Fixing (Where Applicable)

Drawers Supplied in accordance to Specific Customer Kitchen Plan

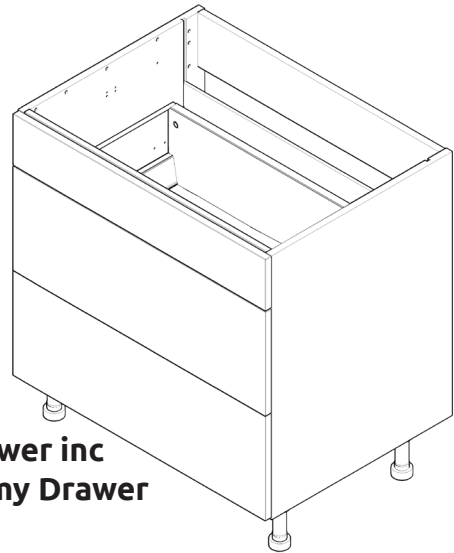

Step 1.

Secure 2 x dummy fixing clip parts **(B)** onto the inside face of dummy drawer front, 22mm from the edge spaced evenly either side as shown, using 21mm screws provided. Align so frontal is in line with adjacent frontals.

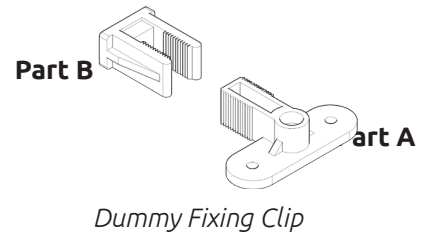
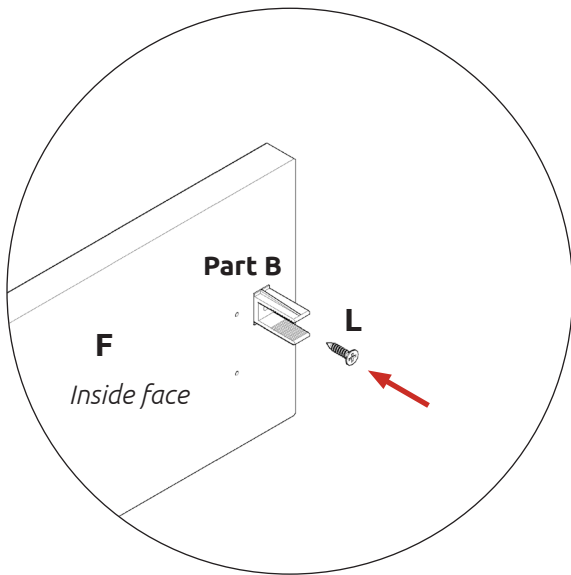

Step 2.

Align and push panel **(F)** into place. Ensure frontal is in line with adjacent units. Space appropriately from unit.

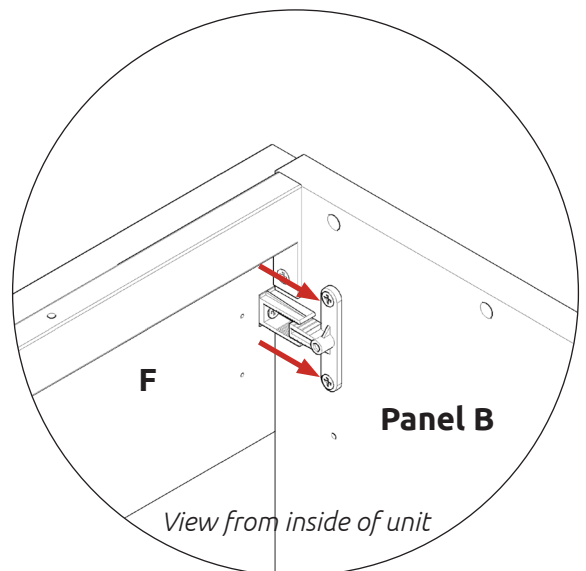

wren
KITCHENS