

Vogue

BASE UNIT

972 L Corner Assembly Guide

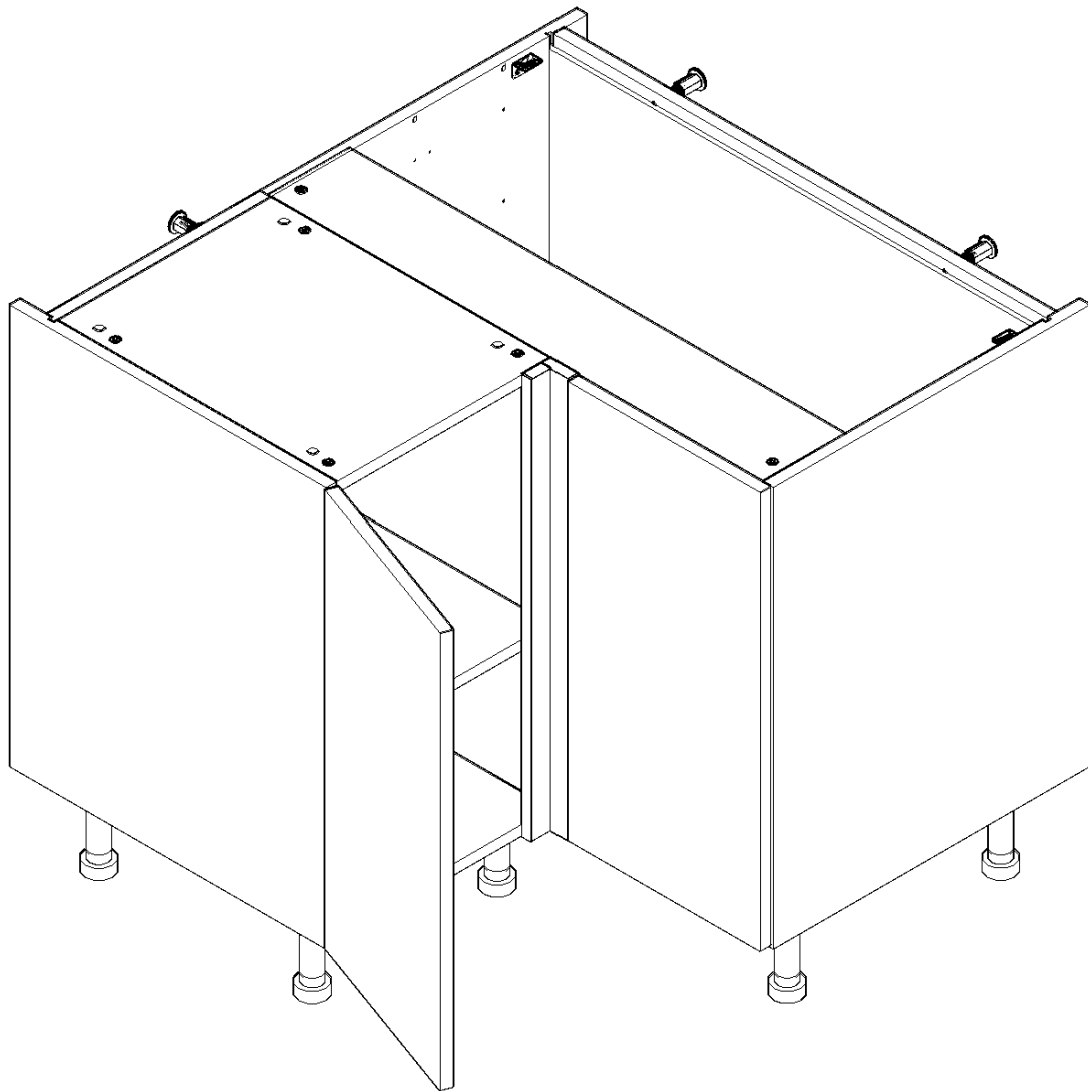

BASE UNIT

972 L Corner Assembly Guide

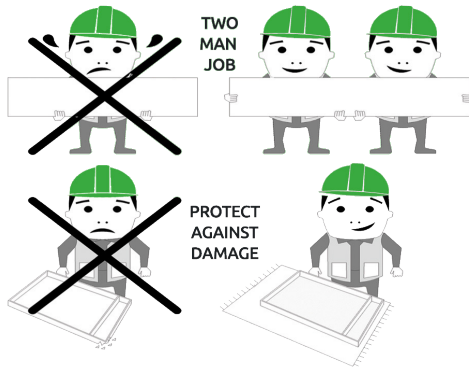

BEFORE YOU START

INSTALLATION SHOULD BE PERFORMED BY A COMPETENT PERSON ONLY.

THIS PRODUCT COULD BE DANGEROUS IF INCORRECTLY INSTALLED

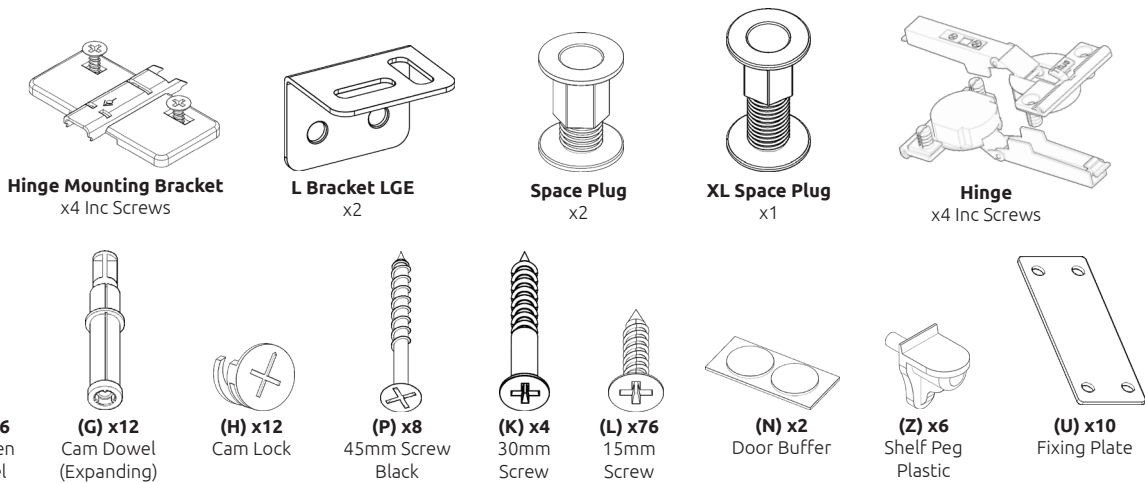
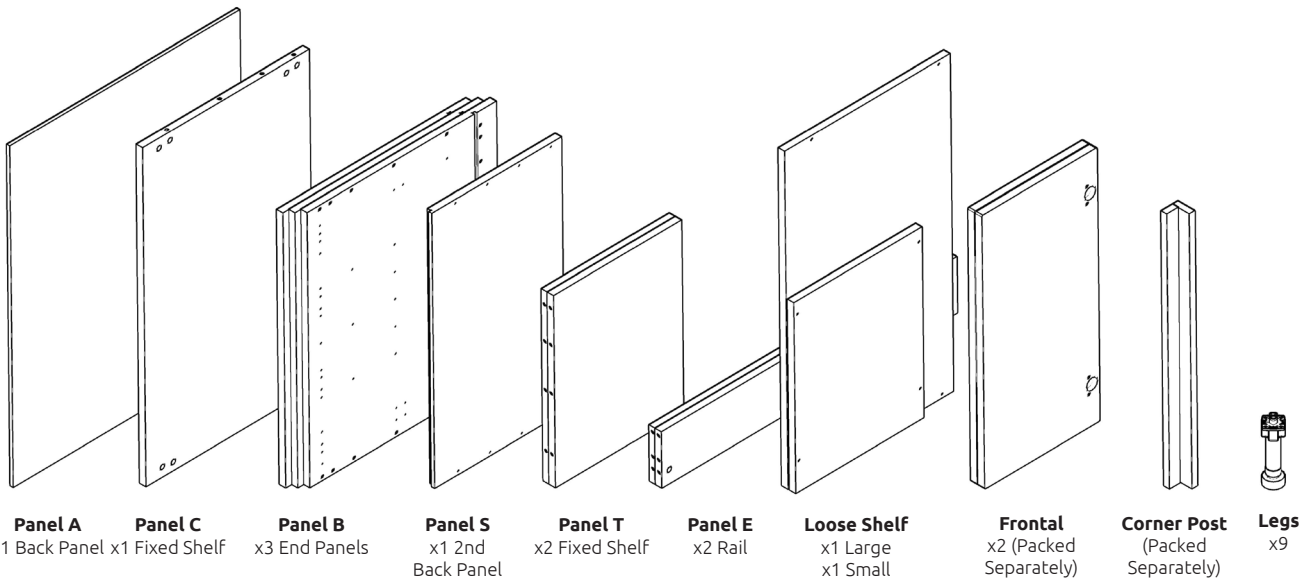

REQUIRED TOOLS

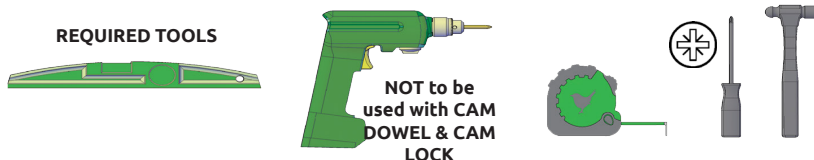

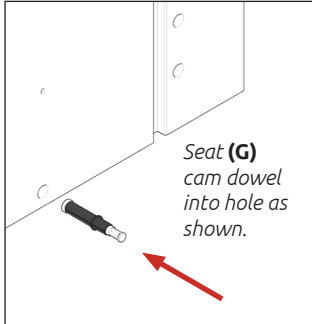

Step 1.
Seat dowel (F) into holes in both end panels (B) as shown.

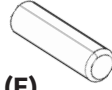

Step 2.
Seat cam dowel (G) into holes in both end panels (B) as shown.

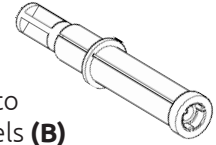

CARCASE 1

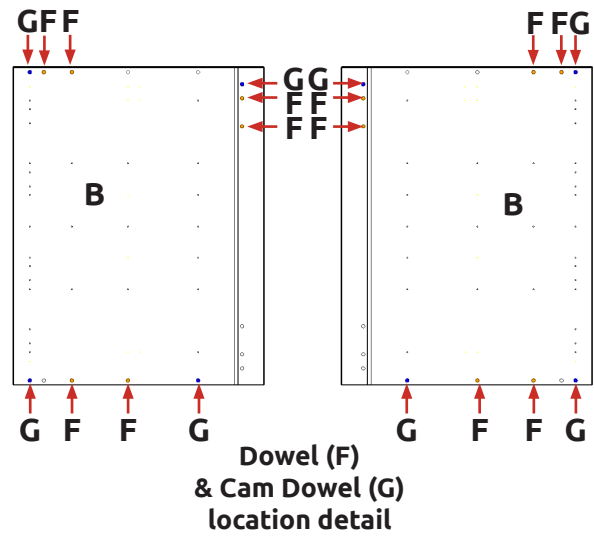
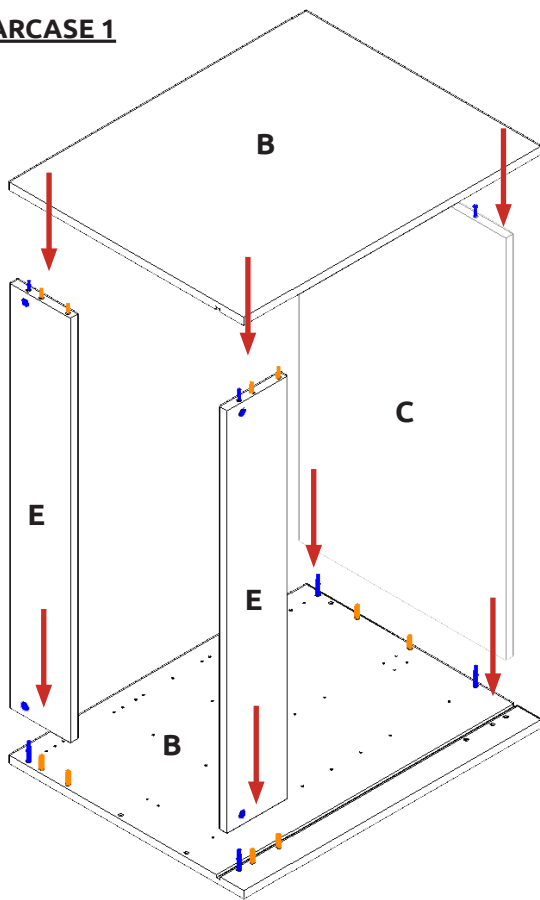

Step 3.
Attach panels (C) to panels (B), using cam dowel (G) (in blue), and also using dowels (F) (in orange) in positions as shown.

 All Cam Locks (H) are to be positioned facing the outside of the unit carcass, for ease of tightening.

Do **NOT** use power tools with cam dowel (G) or cam lock (H)

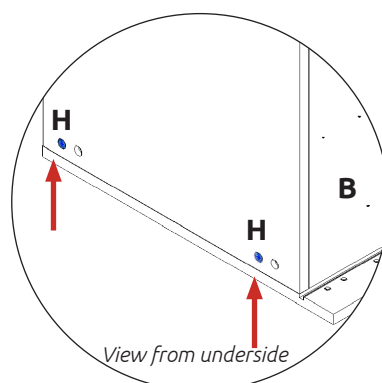
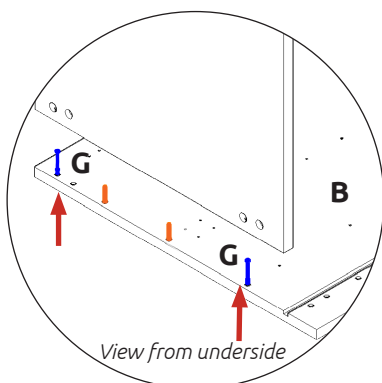

 **Step 4.**
Insert cam lock (H).
Do NOT tighten until Step 6.



BASE UNIT

972 L Corner Assembly Guide

Step 5.

Slide back panel (A) into groove of panels (B).

Once back panel (A) is in position, ensure the panel is flush & square with the bottom of the end panels (B)

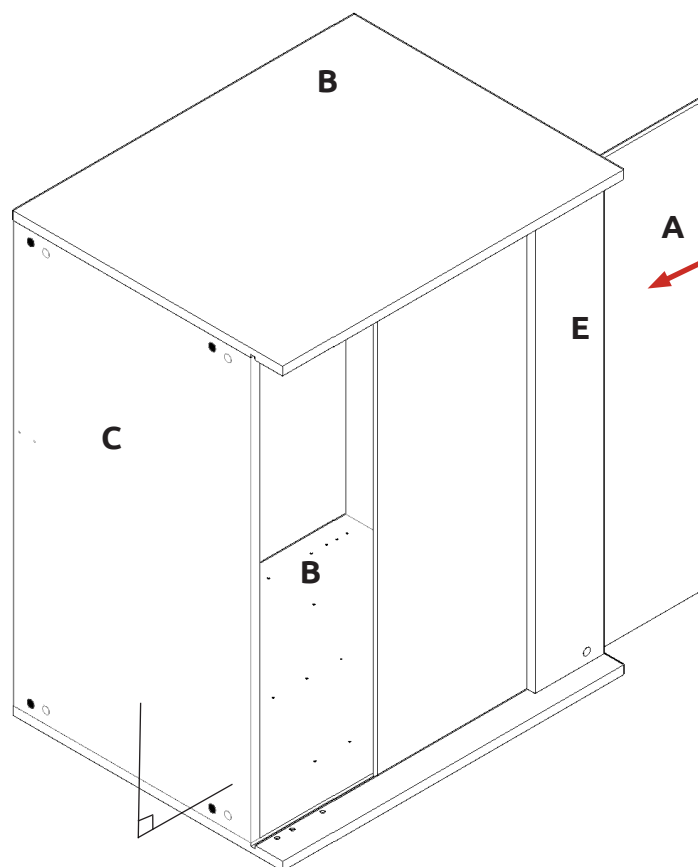

Step 6.

Hand tighten all cam locks (H), this will expand the cam dowels (G) and tighten the unit together.

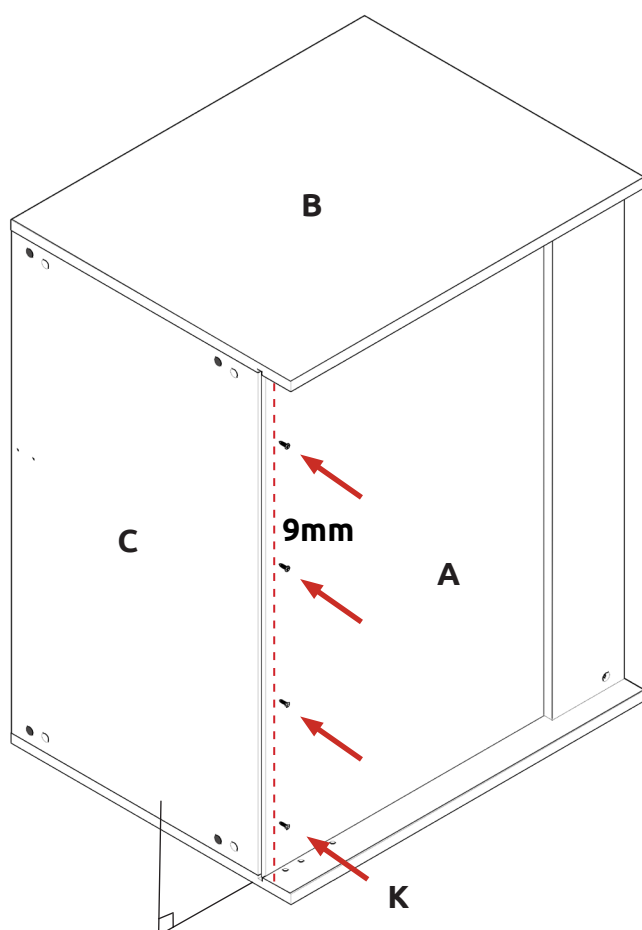

Step 7.

Secure back panel (A) with 4x 30mm screws (K) equally spaced at the bottom of back panel (A) into base panel (C), as shown.

Ensure you screw into the centre of base panel (C) (9mm from the bottom edge).

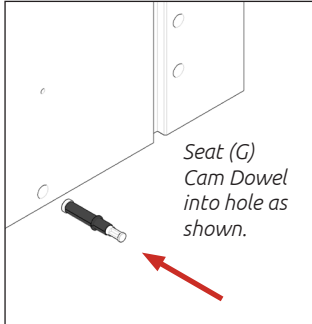

Step 8.
Seat dowel (F)
into holes in
both end panels (B)
as shown.

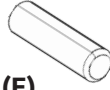

Step 9.
Seat cam dowel (G)
into holes in both end panels (B)
as shown.

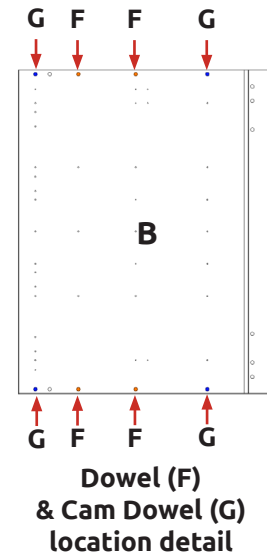
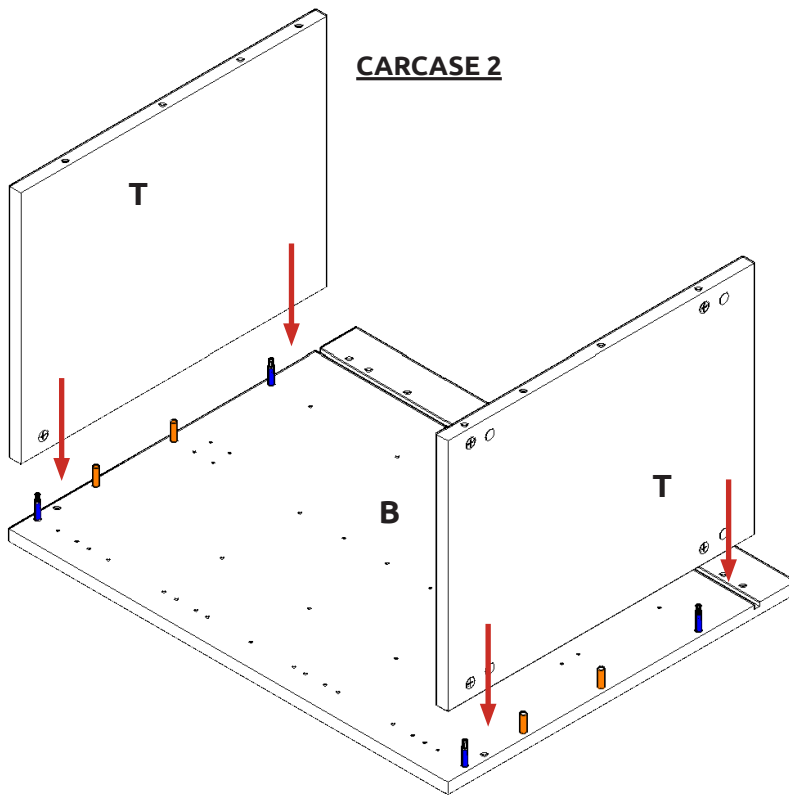
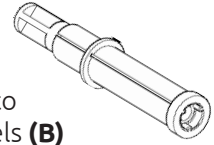

! All Cam Locks (H) are to be positioned facing the outside of the unit carcase, for ease of tightening.

Step 10.
Attach both panels (T) to panel (B), using cam dowel (G) (in blue) and also using dowels (F) (in orange) in positions as shown.

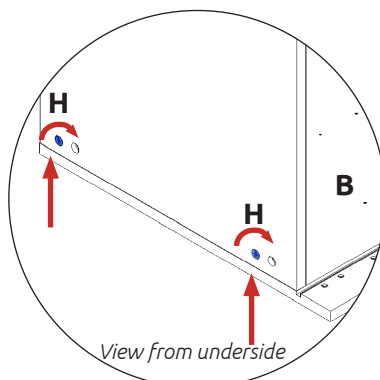
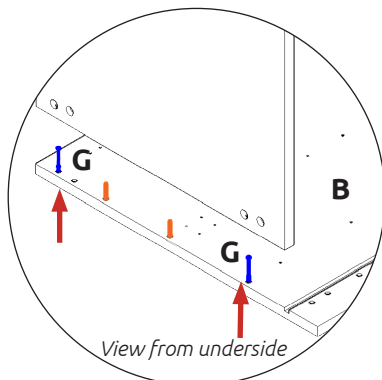

Do **not** use power tools with cam dowel (G) or cam lock (H)

! **Step 11.**
Insert cam lock (H) and hand tighten.

BASE UNIT

972 L Corner Assembly Guide

Step 12.

Secure panel (S) with 4x 45mm screws (P) at the top and 4x 45mm screws (P) in the bottom, in the holes provided as shown.

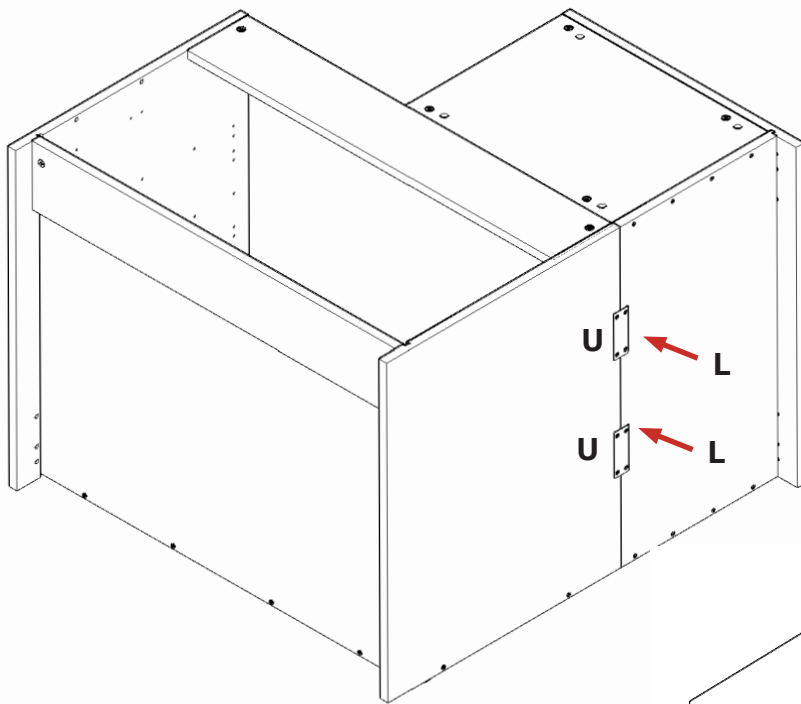
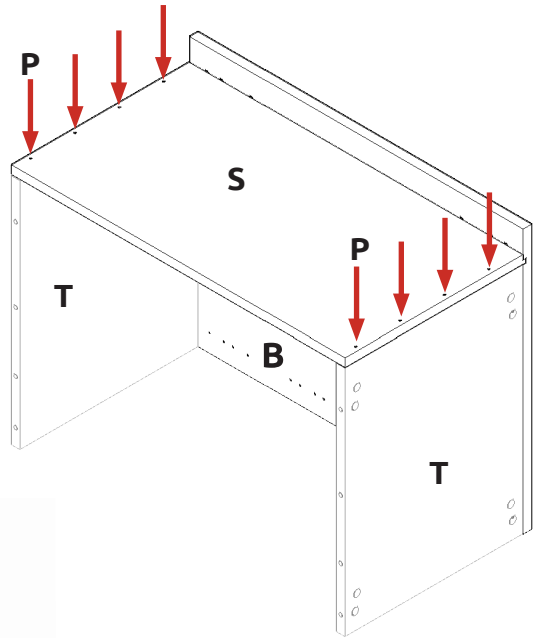

Step 13.

Secure both carcasses together using fixing plates (U) with 4 x 15mm screws (L) to each plate (U). Plates (U) should be positioned equally spaced as shown.

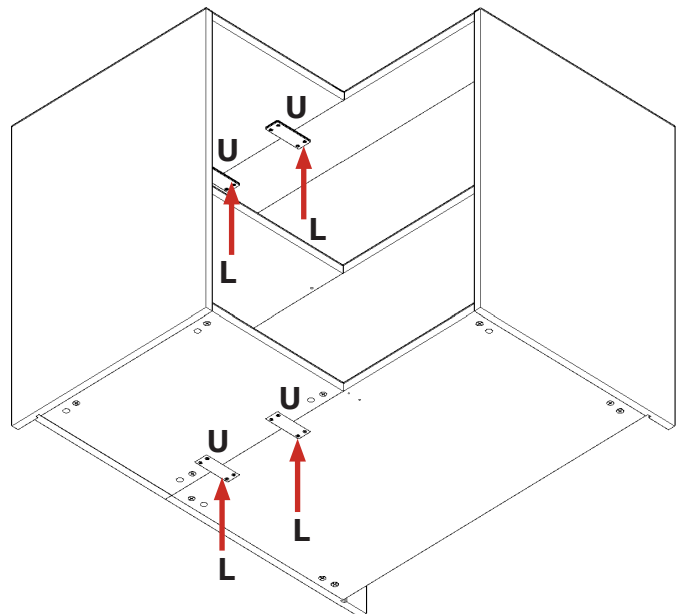

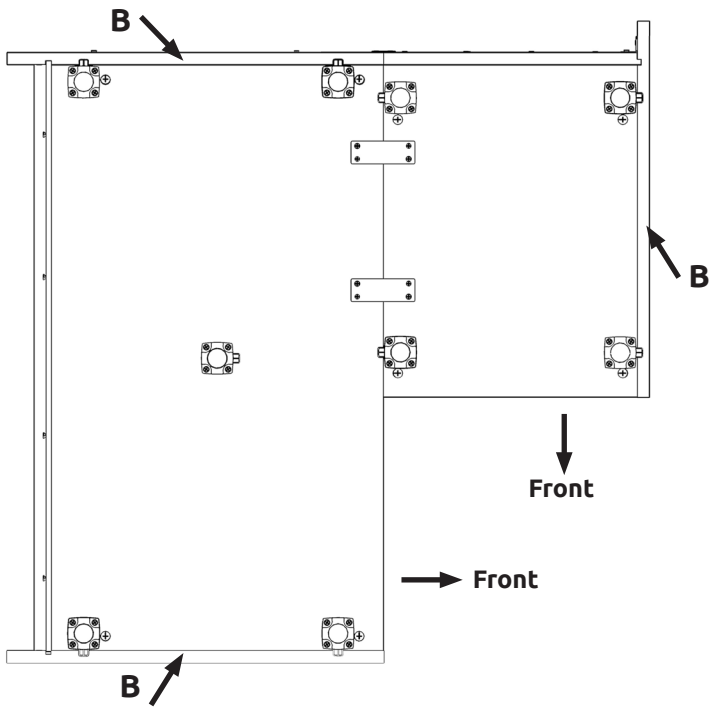

Leg position diagram

Step 15.

Secure each of the legs into place with 4 x 15mm screws (L) per leg.

Step 14.

Position legs as shown. Ensure legs are rotated to also provide support to the end panels (B).

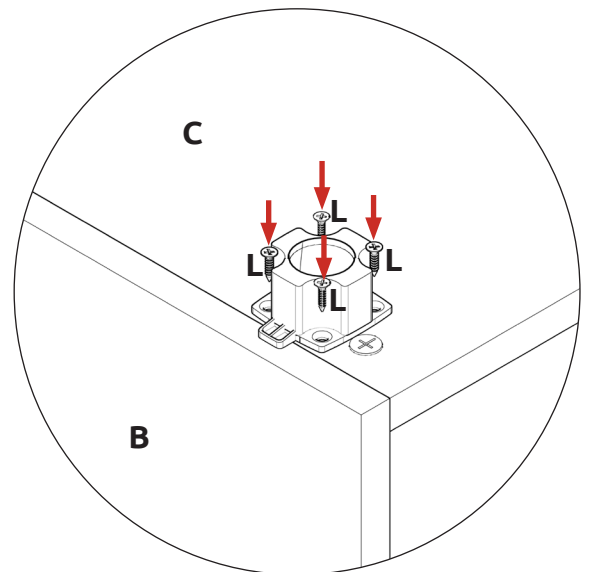

Step 16.

Push leg firmly down into leg base. Adjust legs to 155mm before turning unit upright. Once in situ level accordingly.

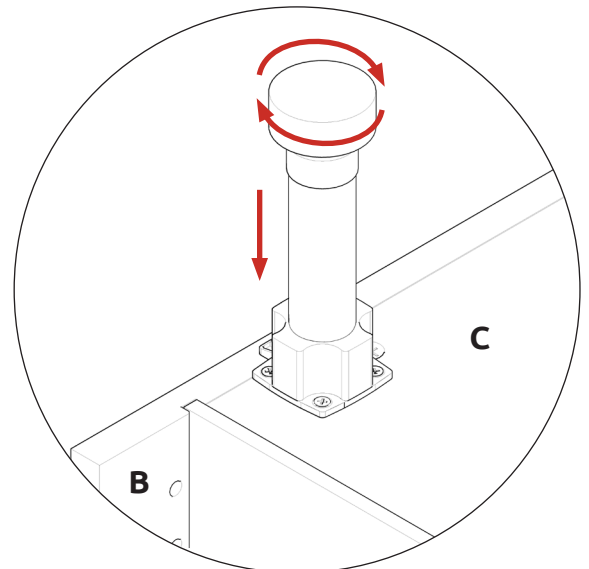

BASE UNIT

972 L Corner Assembly Guide

Step 17.

Attach hinge mounting plate onto both end panels (**B**) as shown, using screws which are already positioned within the hinge plates.

Hinge side or sides to be mounted in accordance to Customer Specific Kitchen Plan.

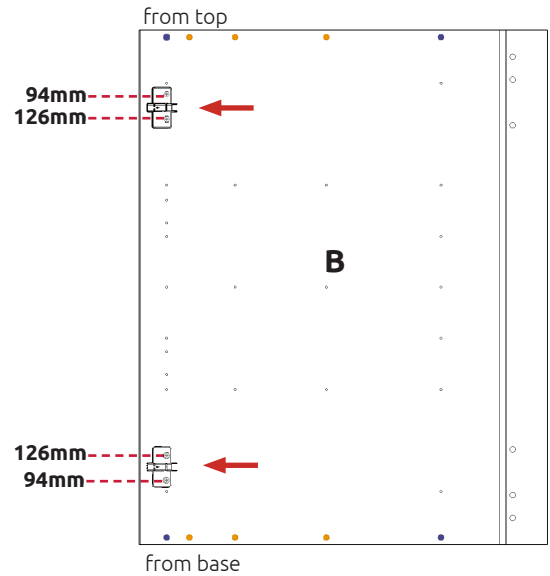
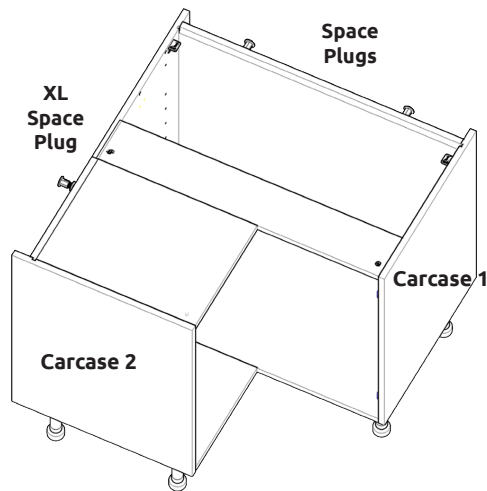

Securing to Adjacent Units

Screw into any side units using the 30mm screws (**K**) provided to secure to unit. Screw just to the rear of the hinge plate at the top and bottom of both sides of the unit, place a cover cap (**M**) on the head to conceal it.

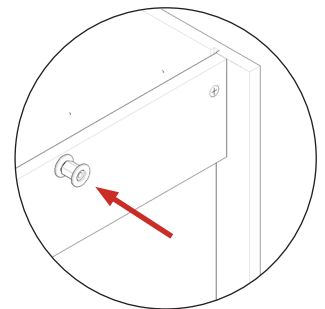
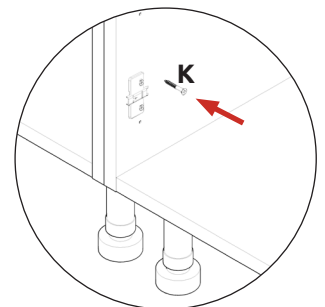

Screws for attaching to walls and worktop are not provided as these vary depending on materials, thickness and construction. Ensure appropriate fixings for wall and worktop construction are used. Please refer to the specialist worktop supplier if these are required for solid surface worktops.

Secure unit to wall using Space Plugs. Drill 2 pilot holes through the back rail of carcase 1 into the wall, drill 1 pilot hole through the back rail of carcase 2 into the wall and insert wall plugs. Then unwind Space-Plugs behind carcase 1 and XL Space-Plug behind carcase 2 until they contact both surfaces. Finally, tighten the screws.

L Brackets

Use 2 x 15mm screws (**L**) to secure each of the L brackets to the units at either side. Then screw up through into the worktop as shown.

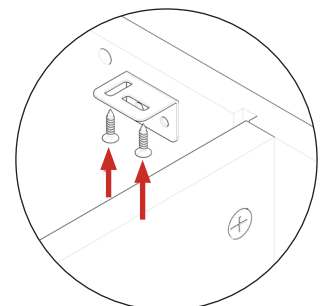
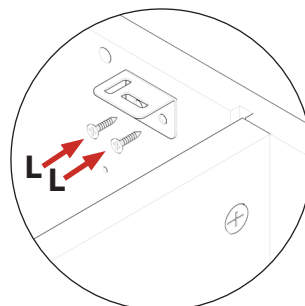
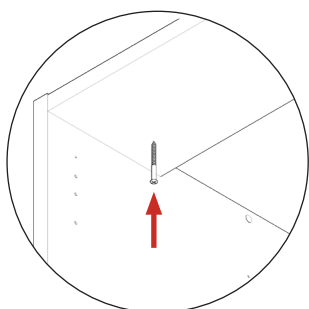

Worktop

Screw up through the front rail into your worktop to secure it in place.

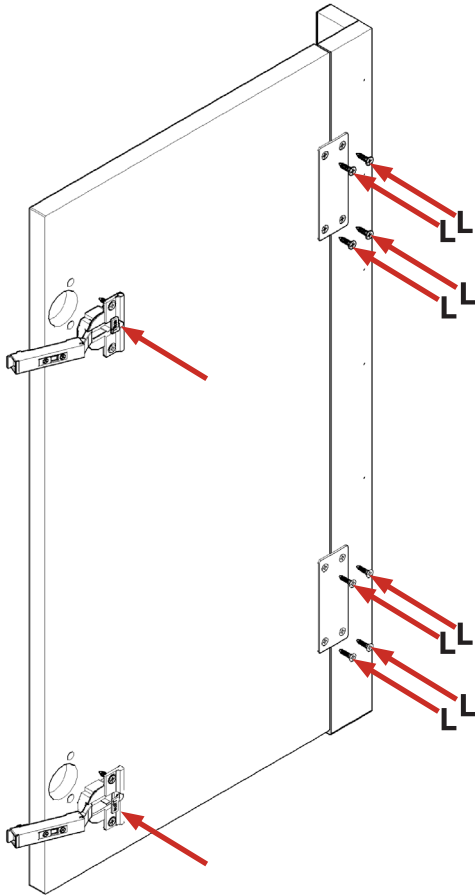

Step 18.

Insert hinge in top & bottom holes as shown below.

Step 19.

Align corner post to frontal. Equally space 2 fixing plates (**U**) to the back of frontal & corner post. Ensure a 4mm gap is maintained between frontal & post once fixed together. Screw in place using 4 x 15mm screws (**L**) per fixing plate (**U**).

Step 20.

Secure hinges by tightening 2 x screws with hinge dowels attached. These are already positioned within the hinges.

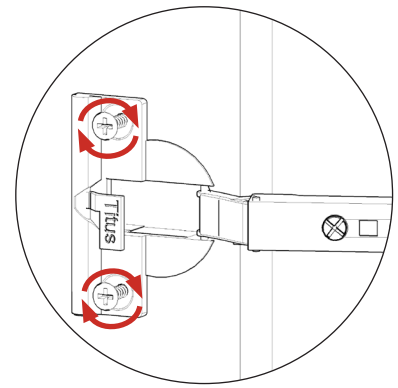

Step 21.

Attach the door to unit where required.

To attach door, clip hinge onto hinge plate and click to secure.

Step 22.

Adjust hinge to suit. As shown below.

<p>FRONTAL HINGE ADJUSTMENT</p>	<p>To adjust hinge using a screw driver, tighten or loosen as required at points 1 & 2. Point 1 - In - Out Point 2 - Left - Right</p>
<p>To Move the hinge up/down, loosen screws A + B, Manoeuvre the door, then re-tighten the screws</p>	<p>To release door, pull catch as shown, to release hinge from the hinge plate.</p> <p><i>View from inside of Unit</i></p>

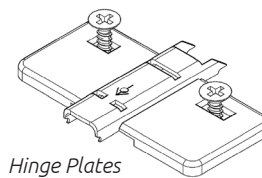

Step 23.

Fit cover caps to hinge. Adjust Soft close to suit.

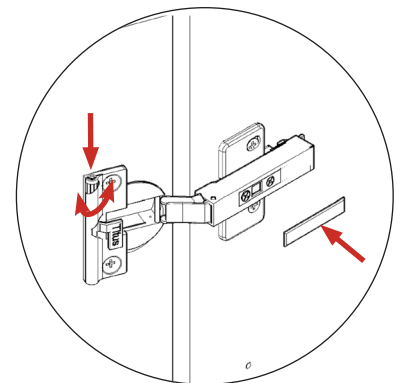
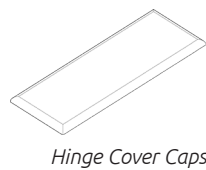

The top and bottom hinges **MUST** be adjusted to the **SAME STRENGTH.**

Vogue

BASE UNIT

972 L Corner Assembly Guide

wren
KITCHENS