

Vogue

BASE UNIT

600 Built Under Oven Housing Assembly Guide

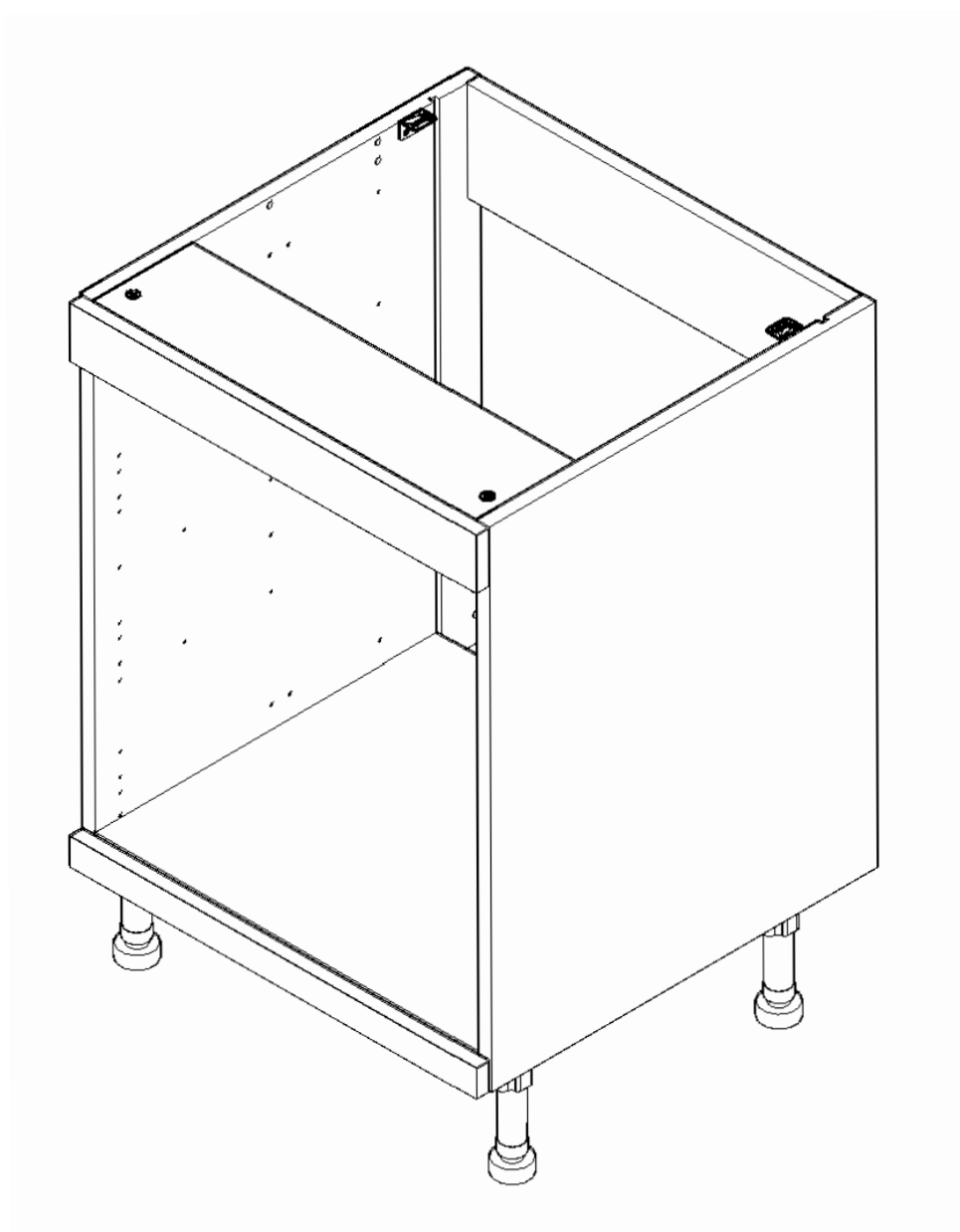

BASE UNIT

600 Built Under Oven Housing Assembly Guide

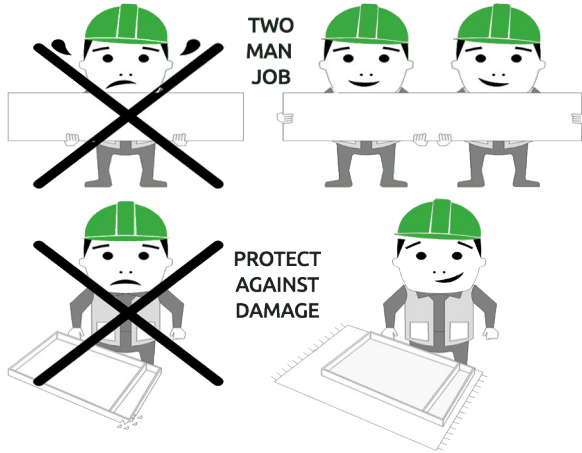

BEFORE YOU START

INSTALLATION SHOULD BE PERFORMED BY A COMPETENT PERSON ONLY.

THIS PRODUCT COULD BE DANGEROUS IF INCORRECTLY INSTALLED

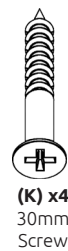
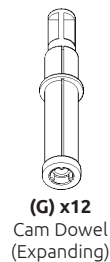
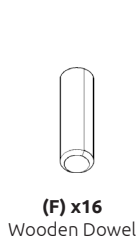
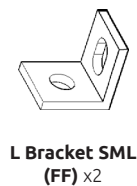
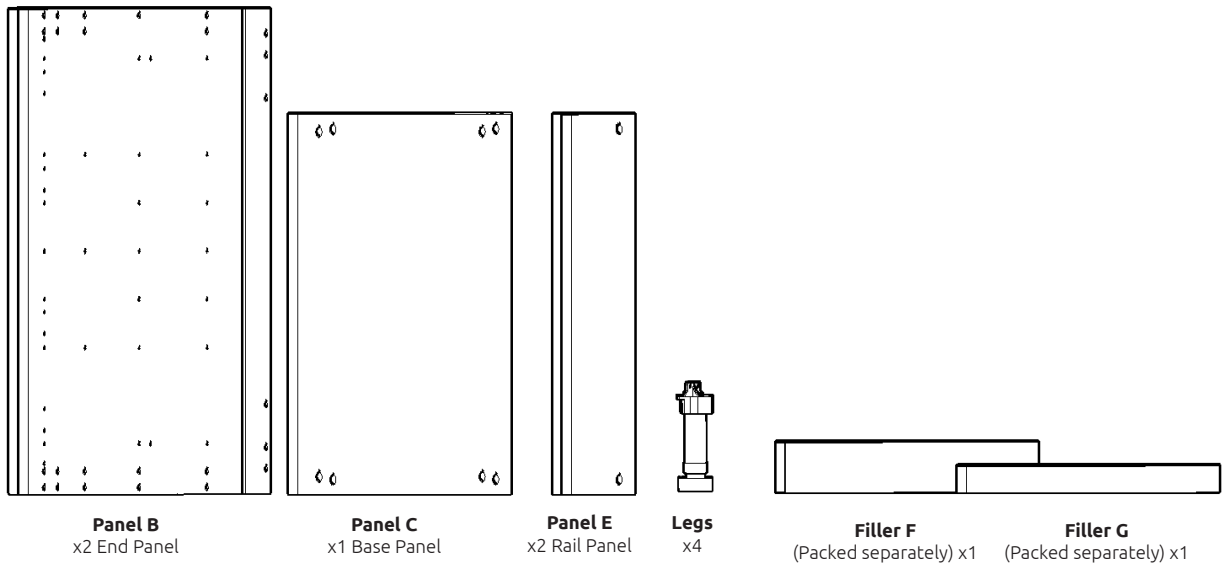

REQUIRED TOOLS

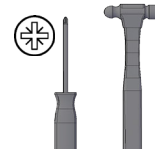

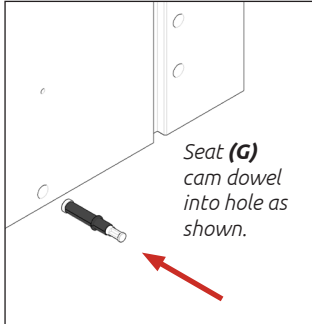

Step 1.
Seat dowel (F) into holes in both end panels (B) as shown.

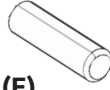

Step 2.
Seat cam dowel (G) into holes in both end panels (B) as shown.

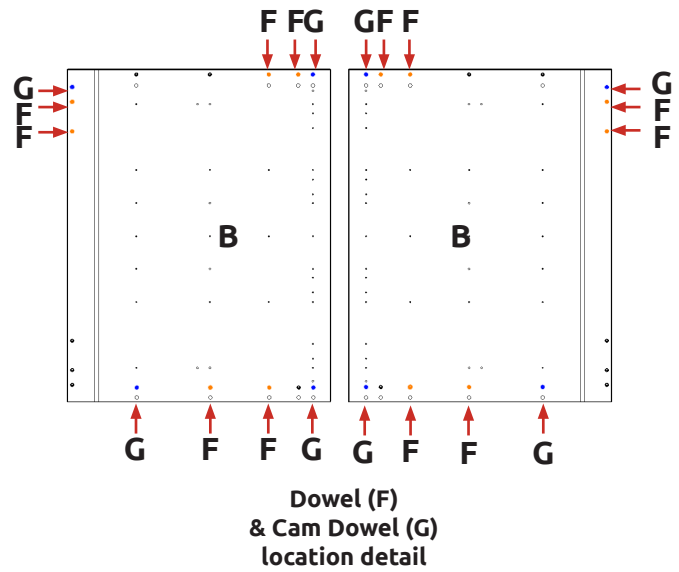
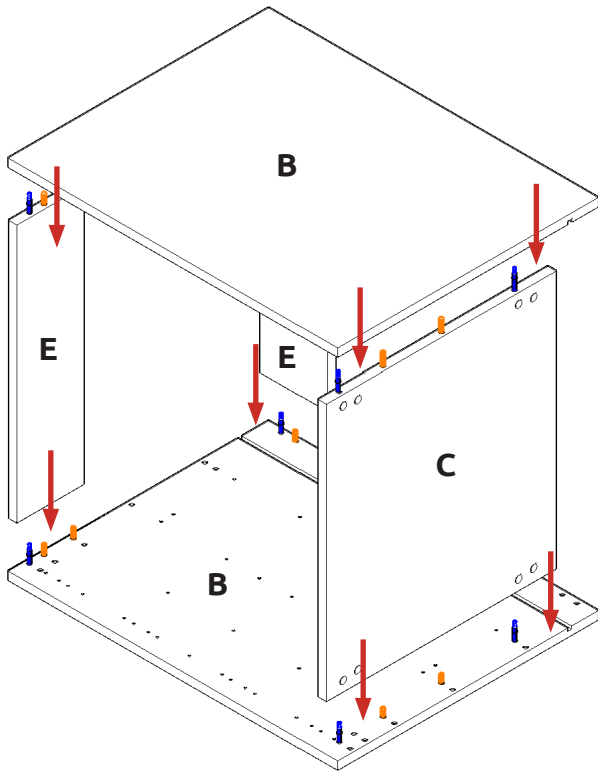
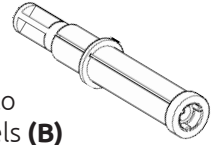

Step 3.
Attach panels (C) & (E) to panels (B), using cam dowel (G) (in blue) and also using dowels (F) (in orange) in positions as shown.

! All Cam Locks (H) are to be positioned facing the outside of the unit carcass, for ease of tightening.

Do **NOT** use power tools with cam dowel (G) or cam lock (H)

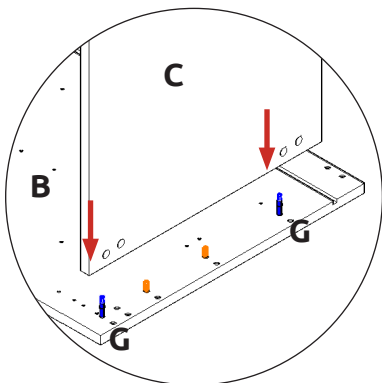

View from underside

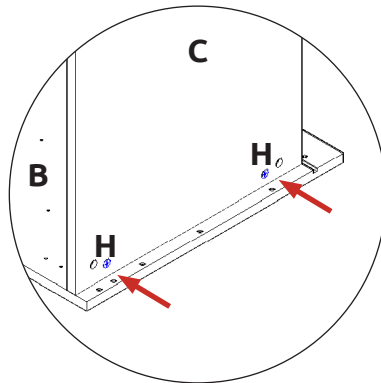

View from underside



Step 4.
Insert cam lock (H) and hand tighten.

BASE UNIT

600 Built Under Oven Housing Assembly Guide

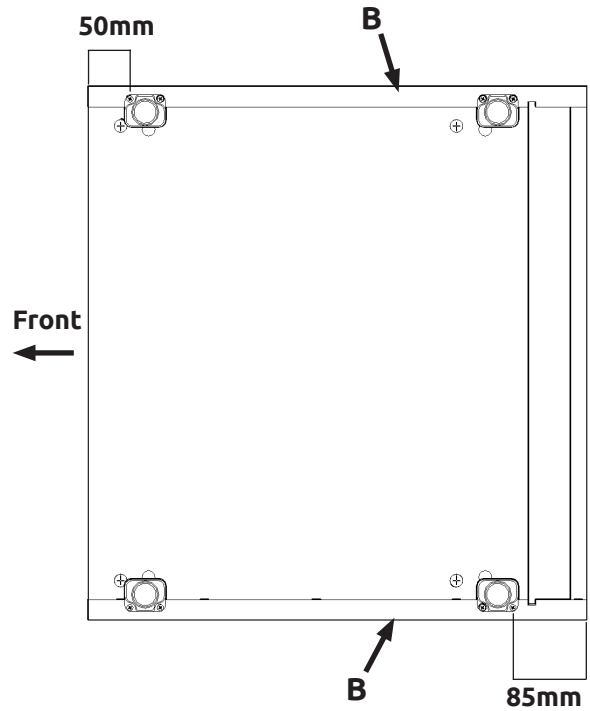
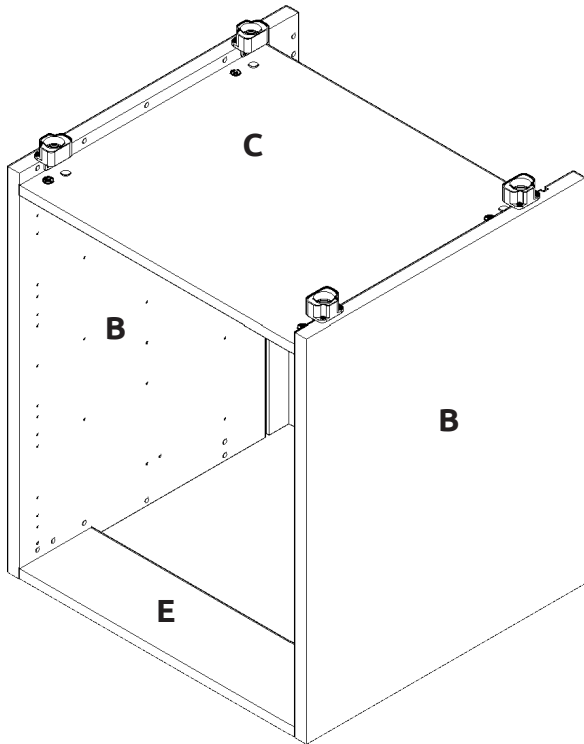

Leg position diagram

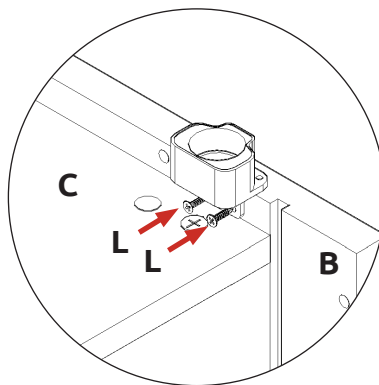
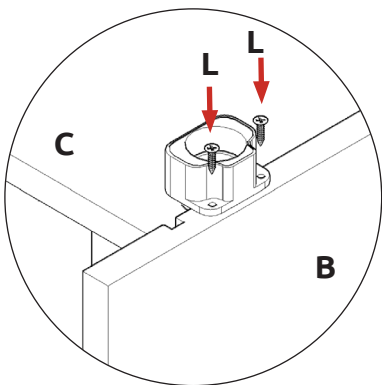

Step 5.

Secure each of the legs into place with 4 x 15mm screws (L) as shown.

Step 6.

Push leg firmly down into leg base. Adjust legs to 155mm before turning unit upright. Once in situ level accordingly.

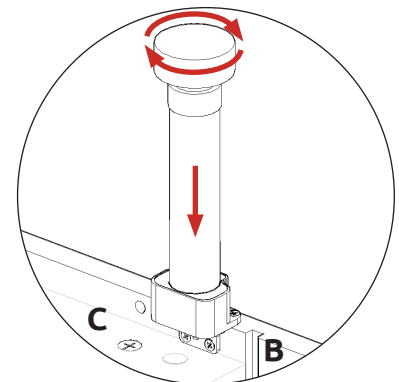

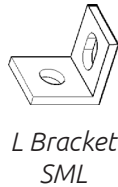

Step 7.

Use 1 x 15mm screw (**L**) per L Bracket SML (**FF**) to secure to inside face of Filler (**G**). Attached equally spaced as shown.

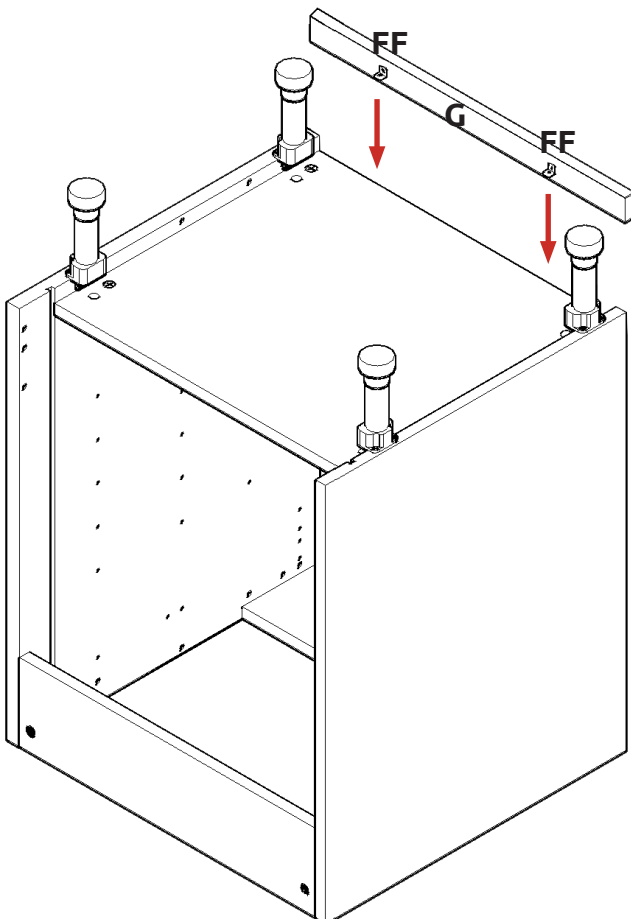
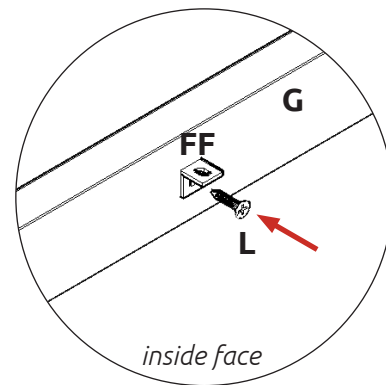
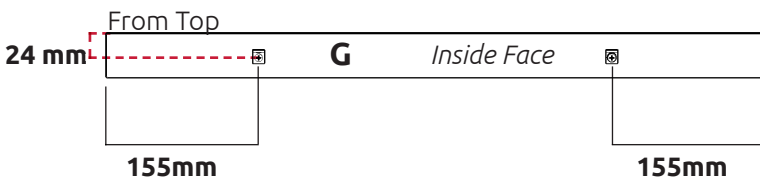

Step 8.

Align Filler (**G**) to unit ensuring it is in line with adjacent frontals. With the Unit upside down secure Filler (**G**) with 1 x 15mm Screw (**L**) per small L bracket (**FF**) to base of unit as shown.

Flip unit upright and move into situ.

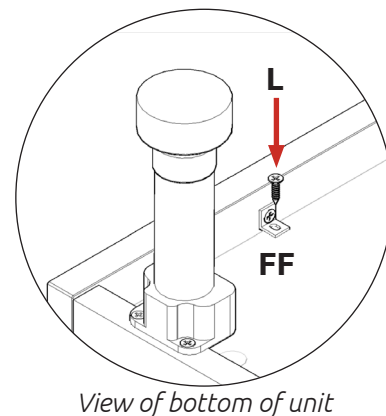

BASE UNIT

600 Built Under Oven Housing Assembly Guide

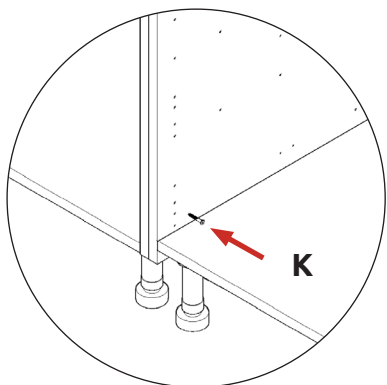

Securing To Adjacent Units

Screw into any side units using the 30mm screws **(K)** provided to secure to unit. Screw at the top and bottom of both sides of the unit, place a cover caps **(M)** on the head to conceal it.



Screws for attaching to walls and worktop are not provided as these vary depending on materials, thickness and construction. Ensure appropriate fixings for wall and worktop construction are used. Please refer to the specialist worktop supplier if these are required for solid surface worktops.

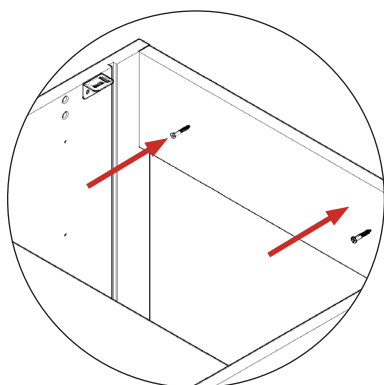

Secure to wall

Screw through the back rail into the wall to secure the unit in place.

L Brackets

Use 2 x 15mm screws **(L)** to secure each of the L brackets LGE to the unit at either side.

Then screw up through into the worktop as shown.

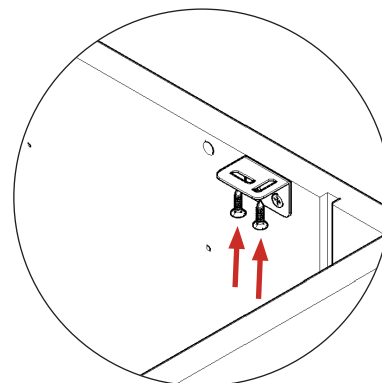
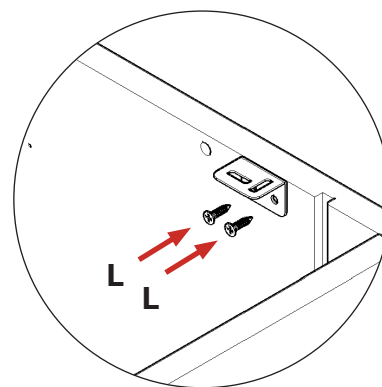

Worktop

Screw up through the front rail into your worktop to secure it in place.

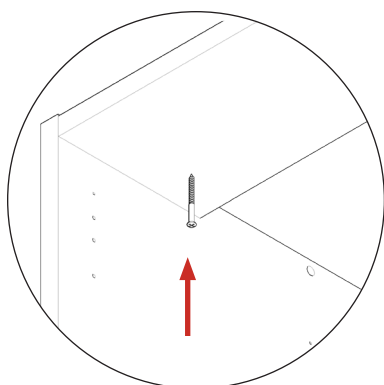

Step 9.

Secure dummy fixing clip (**Parts B**) onto the inside face at the bottom of panel (**F**), 56mm from the top face and 22.5mm from the edges to the screw hole of (**Parts B**), spaced evenly either side as shown, using 1 x 21mm screw per dummy fixing clip (**Parts B**). Align so filler is in line with adjacent frontals.

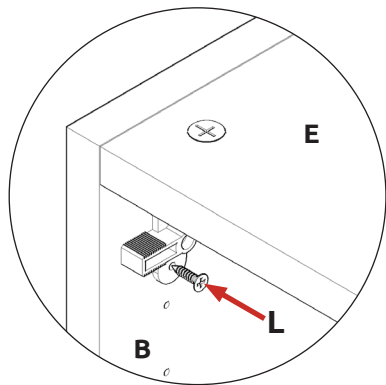
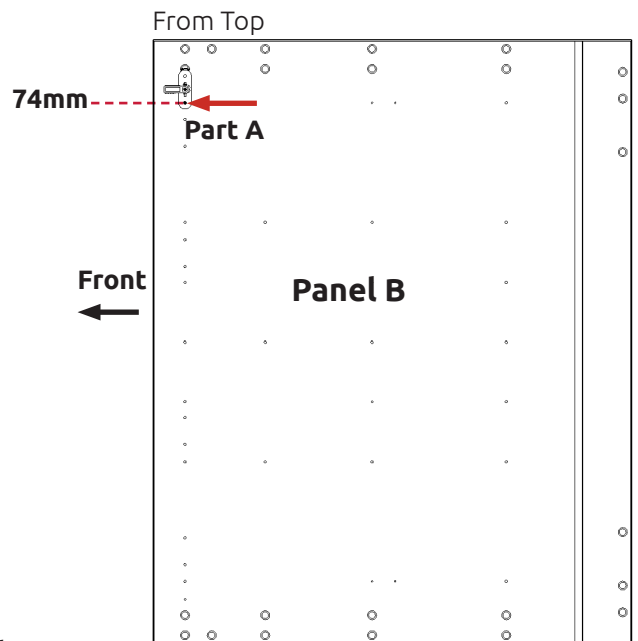
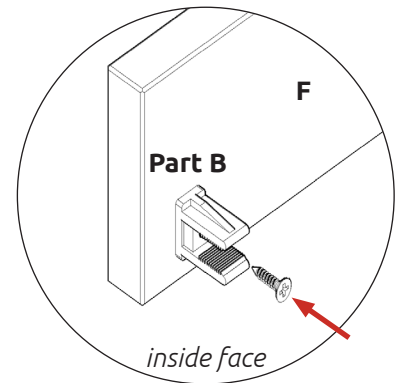
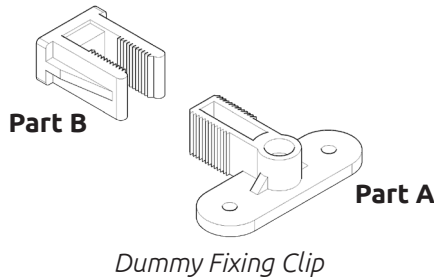

Step 10.

Secure dummy fixing clip (**Parts A**) onto both end panels (**B**) using 2 x 15mm screws (**L**) each, as shown. The bottom screw hole is to be positioned 74mm from the top of the panel using the pre drilled hole.

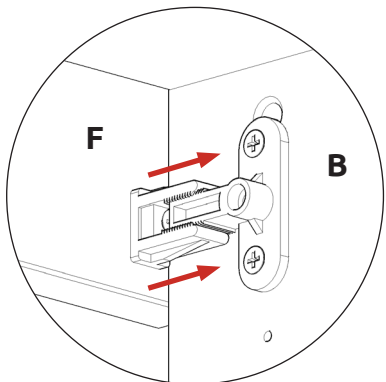

View from inside of unit

Step 11.

Align and push panel (**F**) into place. Ensure filler is in line with adjacent frontals. Space appropriately from unit.

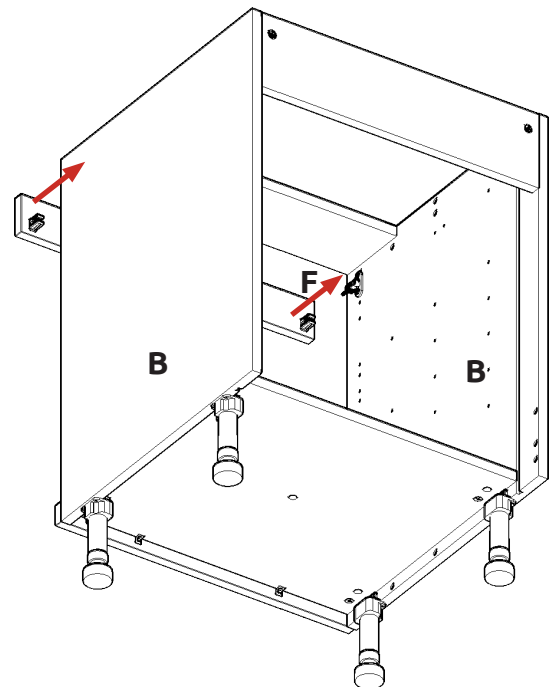

wren
KITCHENS